

Code of Practice
for
Design, Manufacture, Installation, Operation,
Maintenance, Inspection
and
Structural or Major Modification of Trampoline Parks

OIR Disclosure Log

Effective date 12 June 2014

CONTENTS

	Page No.
SECTION 1 SCOPE AND GENERAL	4
1.1 SCOPE	4
1.2 OBJECTIVE	4
1.3 APPLICATION	4
1.3.1 Classification	
1.3.2 Intended users	
1.3.3 Exclusions	
1.4 REFERENCED DOCUMENTS	5
1.5 DEFINITIONS	5
SECTION 2 PLANNING AND DEVELOPMENT	
2.1 FACILITY PROFILE	7
2.2 REGULATIONS	7
SECTION 3 DESIGN	8
3.1 LOADING, DESIGN AND DOCUMENTATION	8
3.1.1 Risk Assessment	8
3.1.2 Loads and Strengths	8
3.1.3 Patron Weight	
3.1.4 Live Loads	8
3.1.5 Detail Design	9
3.1.6 Drawings and Records	9
3.2 SAFETY REQUIREMENTS	10
3.2.1 Patron Containment	10
3.2.2 Patron Containment Systems	10
3.2.3 Netting	11
3.2.4 Dismount Surface	12
3.2.5 Impact Attenuating Material	13
3.3 LAYOUT AND INSTALLATION	14
3.3.1 Assembly Area	14
3.3.2 Obstructions	14
3.3.3 Trampoline Court Foam Pits	16
3.3.4 Inflatable Bags as Foam Pit Replacement	19
3.3.5 Trampoline Frame	20
3.3.6 Trampoline Bed	20
3.3.7 Trampoline Suspension System	21
3.3.8 Patron Barriers	21
3.3.9 Installation	22
3.3.10 Fans	22
3.3.11 Electrical	22
3.3.12 Suspension Ropes and Chains	22
3.3.13 Welding	23
3.3.14 Metal Structures	23
3.3.15 Bolted Connections	23
3.4 STATEMENT OF COMPLIANCE WITH CODE OF PRACTICE BY COMPETENT PERSON	25
3.5 INFORMATION TO BE PROVIDED BY THE MANUFACTURER OR SUPPLIER OF NETTING OR IMPACT ATTENUATING MATERIAL	25
3.5.1 Containment Net, Safety Net or Small Mesh Material	25
3.5.2 Impact Attenuating Material	25
3.5.3 Trampoline Bed	26
3.5.4 Trampoline Court	26
3.5.5 Foam Pit	26

SECTION 4	SPECIFIC TRAMPOLINE EQUIPMENT REQUIREMENTS	26
4.1	MOVEABLE DEVICES	26
4.2	MOVABLE SYSTEMS	26
4.3	INFLATABLE DEVICES	26
4.4	PROHIBITED DEVICES	27
4.5	MAJOR MODIFICATIONS	27
SECTION 5	OPERATION	28
5.1	GENERAL	28
5.2	OWNER/OPERATOR [PCBU] RESPONSIBILITIES	28
5.2.1	Policies and Procedures	28
5.2.2	Operating times/frequencies	28
5.2.3	Communication Systems	28
5.2.4	Crowd Control	28
5.2.5	Signage	28
5.2.6	Evacuation Plan	28
5.2.7	Emergency Lighting	28
5.3	STAFFING	29
5.3.1	Staffing to manage courts	29
5.3.2	Factors affecting staffing	29
5.3.3	Minimum Staffing	29
5.3.4	Ratio Staff to Patrons	29
5.3.5	Responsibilities	29
5.3.6	Behaviour Control	29
5.4	STAFF TRAINING	29
5.4.1	Document Training	29
5.4.2	First Aid	29
5.5	FACILITY OPERATION	29
5.5.1	General	29
5.5.2	High Performance Trampolines	30
5.6	PATRON EDUCATION	30
5.7	PATRON RESPONSIBILITY	31
5.8	EMERGENCY PROVISIONS AND PROCEDURES INCLUDING REPORTABLE INJURIES	31
5.8.1	Regulator Requirements	31
SECTION 6	INSPECTION, MAINTENANCE AND CLEANING	33
6.1	INFORMATION REQUIREMENTS	33
6.2	SPECIFICATIONS FOR INSPECTION, MAINTENANCE and REPAIR	33
6.3	INSPECTION AND MAINTENANCE PROGRAM	33
6.4	REPLACEMENT POLICY	33
APPENDICES		
APPENDIX A	METHODS FOR CALCULATION OF STRUCTURAL INTEGRITY	34
APPENDIX B	PHYSICAL TESTING OF STRUCTURAL INTEGRITY	36
APPENDIX C	DETERMINATION OF HIC, HIC DURATION, G_{max} AND j_{max} VALUES	38
APPENDIX D	INSPECTION INFORMATION AND SCHEDULES	41
APPENDIX E	TEST METHOD FOR BARRIERS, NETTING, MESH AND ATTACHMENT PERFORMANCE	43
APPENDIX F	TEST METHOD FOR ULTRA VIOLET (UV) RESISTANCE	45
APPENDIX G	TEST METHOD FOR FRAME-PADDING AND SOFT-EDGE SYSTEMS	47
APPENDIX H	TEST METHODS FOR ENTRAPMENT	51

SECTION 1 SCOPE AND GENERAL

1.1 SCOPE

1.1.1 The purpose of this Code of Practice is to outline the requirements regarding the design, manufacture, installation, operation, maintenance, inspection and structural or major modification of commercial trampoline parks whose primary purpose is the provision of amusement, entertainment or recreation.

1.1.2 This Code of Practice applies to any commercial trampoline park that allows public access with, or without, payment of an admission fee or other form of consideration.

1.1.3 This Code of Practice establishes guidelines that will provide a level of uniformity for the purpose of reducing potential hazards to patrons, court attendants, and spectators.

1.1.4 This Code of Practice does not purport to address all of the hazards associated with trampoline parks. The existence of the Code of Practice alone will not prevent injuries. Like other physical activities, trampoline court use involves the risk of injury, particularly if the equipment is used improperly or if users exceed their capabilities, endurance, training, or experience.

1.1.5 This Code of Practice includes addenda which provide additional information to assist understanding and application of the criteria presented.

1.2 OBJECTIVE

1.2.1 This Code of Practice has been prepared by the Australian Trampoline Park Association [ATPA], a sub-committee of AALARA.

1.2.2 This Code of Practice is intended to provide consistent criteria in regard to the specification, construction, operation and management of commercial trampoline parks for the ultimate safety of end users and staff.

1.3 APPLICATION

1.3.1 This Code of Practice is for use by architects, designers, engineers, construction contractors, manufacturers, inspectors, Regulators, owners and operators who are involved with the design, construction, manufacture, installation, operation, maintenance, inspection or any structural or major modification of commercial trampoline parks, whether domestically built or imported.

1.3.2 The structural/dimensional specifications of this Code of Practice will not be required to be implemented retrospectively for existing venues, although should a venue carry out building or structural changes, it would be strongly recommended that the opportunity be taken to comply with the requirements of this Code of Practice. For the reduction of potential risk to patrons, visitors & staff, it is recommended that all parks retrospectively comply with this Code of Practice.

1.3.3 The operational requirements of this Code of Practice shall be implemented in all venues within 3 months of the Code being adopted by APTA and being made publically available. Any modifications to an existing venue must comply with this Code of Practice.

1.3.4 Compliance with Code of Practice

The owner/operator of a trampoline park shall engage a competent person to carry out an audit of the trampoline court and issue a certificate to confirm that the design, installation and operation is in accordance with this Code of Practice. See Clause 3.4 for details of Certificates.

1.3.5 This Code of Practice does not apply to:

- a) Consumer [private] trampolines; trampolines intended for use on water; trampolines primarily used for professional exhibition; or single user trampolines primarily, but not exclusively, used under the direct supervision of a trainer or coach.
- b) Stand-alone commercial trampoline units that consist of one or more individual stations with a total bed area less than 24m² and which employ a mechanical harnessed system to control or direct the descent of a patron.
- c) Amusement devices known as Bungy Trampolines, where there are single users harnessed to bungy cords over an individual trampoline.

1.4 REFERENCED DOCUMENTS

AS 1394	Round Steel Wire for Ropes
AS 1554	Structural steel welding
AS 1554.1 Part 1:	Welding of steel structures
AS 1554.2 Part 2:	Stud welding (steel studs to steel)
AS 1554.3 Part 3:	Welding of reinforcing steel
AS 1554.4 Part 4:	Welding of high strength quenched and tempered steels
AS 1554.5 Part 5:	Welding of steel structures subject to high levels of fatigue loading
AS 1554.6 Part 6:	Welding stainless steels for structural purposes
AS 2118.3	Automatic Fire Sprinkler Systems
AS 2321	Short Link Chain for Lifting Purposes
AS 2759	Steel wire rope—Use, operation and maintenance
AS 3533.1 2009	Amusement rides and devices – Design and Construction
AS 3533.2 2009	Amusement rides and devices - Operation and maintenance
AS 3533.4.1 2005	Amusement rides and devices - Specific requirements—Land-borne inflatable devices
AS 3569	Steel wire ropes
AS 3990	Mechanical equipment—Steelwork
AS 4100	Steel structures
AS/NZS 2293.2.	Emergency Evacuation Lighting for Buildings
AS/NZS 3000	Electrical installations (known as the Australian/New Zealand Wiring Rules)
AS/NZS 3002	Electrical installations—Shows and carnivals
AS/NZS ISO 31000	Principles of Risk management
OTHER DOCUMENTS	
BCA	Building Code of Australia Australian Uniform Building Regulations Co-ordinating Council
WHS Regulations 2012	
WHS Act 2011	
Vic OH&S Act 2004	
ISO 15025	Protective Clothing
ISO 6487	Measurement Techniques in Impact Tests
BS 3408:1992	Specification for Tarpaulins
BS 5438	Methods of test for Flammability of Textiles
ASTM D 638 v ISO	Tensile Properties of Plastic
AATCC Method 169 v ISO	Test Method for Weather Resistance of Textiles

1.5 DEFINITIONS

Active participants are those patrons who are currently authorised to be active in the trampoline court.

Air bag inflatable dismount device is an inflated device that is used to facilitate mounting or dismounting of the trampoline beds.

Arena is the area within a trampoline park that is occupied by trampoline courts or assembly areas.

Assembly area, a designated area primarily used for mounting or dismounting the trampoline court.

Commercial trampoline, a trampoline intended for use in a commercial facility

Competent person is a person who has acquired through training, qualifications or experience, or a combination of these, the knowledge and skills enabling that person to perform a specified task.

Court attendant is an individual trained in facility emergency procedures, familiar with fundamental trampolining and trampoline court foam pit operations, monitoring patrons, controlling patron numbers and responding to trampoline court, and trampoline foam pit emergencies.

Foam pit bed mount is a trampoline bed installed within the foam pit, suspended above the pit floor, supporting the foam blocks.

Mount / dismount platform, any surface within or adjacent to a trampoline area for standing, walking, sitting, or climbing.

Netting Soft Flexible mesh netting used for perimeter/court containment or moveable trampoline park/court dividers

Normal operation means the use of the trampoline court in the manner for which it was designed, including size, weight and number of simultaneous users and required number of court attendants.

Owner/operator, person, entity or organization that is responsible for the maintenance and operation of a trampoline park.

Patron clearance envelope is that area above the trampoline beds [MINIMUM 4000mm high for commercial trampolines and 5000mm high for performance trampolines] and the total area under the trampoline beds that shall be kept clear of any obstruction.

PCBU is a person conducting a business or undertaking. This is normally the business owner or proprietor and may be a company.

Performance trampoline is a trampoline, whose bed is constructed of string or web material to enhance performance, and which is intended for use in a commercial facility.

Performance Walls are raised walls above trampoline bed height used for performance related trampoline activity.

Rest areas are horizontal surfaces within the trampoline court that allow participants to sit or stand while recovering from physical exertion.

Suspension system is a bed-supporting system made up of elastic devices that connect the bed of the trampoline to the frame of the trampoline e.g. steel extension springs.

Trampoline Park is a venue with multiple trampolines and/or trampoline courts.

Trampoline court foam pit is a dismount pit, within a trampoline court, filled with loose impact absorbing blocks.

Trampoline bed is a flexible surface which the user contacts in the course of bouncing on a trampoline.

Trampoline court is a defined area comprising commercial trampolines, containment devices and mount/dismount areas.

SECTION 2 PLANNING AND DEVELOPMENT

2.1 FACILITY PROFILE

The design parameters for the facility shall be decided taking into consideration the following:

- (a) The facility location and type, e.g. within an existing building, within its own purpose-built area or part of an existing business.
- (c) The type of equipment to be provided.
- (d) The intended age groups.
- (e) Whether different age groups are to be provided with separate areas.
- (f) How special needs and disabilities of children and adults are to be addressed.
- (g) Supervision requirements.
- (h) Whether the facility is to be used for functions and private events.
- (j) The intended opening hours.
- (k) The arrangements for customer access and parking, including access and egress for emergency vehicles.

Once the profile of the facility has been decided, a risk assessment in accordance with AS/NZS ISO 31000 shall be carried out and documented, covering the construction, operation, maintenance, inspection, cleaning and staffing of the facility.

2.2 REGULATIONS

Any Local or State Government regulations covering the following aspects shall be taken into account:

- (a) Child welfare.
- (b) Environmental health.
- (c) Food hygiene.
- (d) Health and safety.
- (e) Noise.
- (f) Planning and building controls, including Building Code of Australia requirements.
- (g) Heating and air-conditioning/ventilation (mechanical and electrical) considerations.
- (h) Fire precautions, fire safety management and means of evacuation.
- (i) Compliance with WHS regulations.

SECTION 3. DESIGN.

3.1 LOADING, DESIGN AND DOCUMENTATION

3.1.1 Risk Assessment

The designer shall carry out and document a risk assessment that shall include the following:

- a) An assessment of the suitability of the design of the trampoline court for the intended patrons, including anthropomorphic factors that relate age and physical size, and consequent clearances required for the patron clearance envelope.
- b) Any significant hazard within the trampoline court that may affect patron safety and shall include the means to eliminate or reduce the risk for each hazard identified. Specific attention shall be given to light globes and fittings i) to protect them from damage by impact from balls or missiles and ii) to ensure broken or damaged items or parts cannot fall onto patrons. See also Clause 3.3.11 of this Code of Practice.
- c) During the design risk assessment, the following shall be taken into consideration to ensure the safe egress of patrons in the event of a fire:
 - i. Materials of construction.
 - ii. Flammability of materials.
 - iii. Guarding to prevent breakage of or damage to electrical fittings.
 - iv. Effects on patrons of gases, retardants and fumes.
 - v. Time for patron to exit structure.
 - vi. Exit paths.

3.1.2 Loads and Strengths:

Trampoline park arenas shall be designed so that failure of the structures will not occur under design loading and duration as determined in 3.1.5.4.

3.1.3 Patron Weight:

The weight assigned to an adult or child patron, for design purposes, shall be 75kg.

The designer may assign higher weight values for design purposes in accordance with the requirements of this Code of Practice or the intended usage of the final product.

As a non-fatigue, dynamic case, trampoline courts shall be designed for occasional full or partial loads of large adult participants, potentially weighing 140 kg per participant or a lesser maximum weight, if recommended by the trampoline manufacturer.

3.1.4 Live loads for a trampoline court include all loads that vary with time and are divided into five types:

3.1.4.1 Operational Loads:

All the varying loads normally encountered during operation of the trampoline court.

3.1.4.2 Non-operational Loads:

All loads associated with transportation, or handling, or both (that is, setting up, tearing down) and ongoing maintenance of portable and permanent trampoline courts.

3.1.4.3 Environmental Loads:

Portable trampoline courts shall be designed to resist all environmental loads specified by the designer.

The designer shall identify the environmental loads for which the trampoline court was designed.

Fixed or permanent trampoline courts shall be designed to resist all environmental loads in accordance with the applicable building codes for their location.

In the operating and maintenance instructions, in addition to the environmental load information, any restrictions, limitations, or special procedures resulting from exposure to these environmental loads shall be specified.

3.1.4.4 Operation in Wind:

As a minimum, trampoline courts exposed to wind shall be designed to operate in wind speeds up to 15 m/s [54 kph.].

The designer or manufacturer shall include, in the operating and maintenance instructions, any restrictions, limitations, or special procedures for the safe operation of a trampoline court exposed to wind.

3.1.4.5 Non-operational in Wind:

The designer or manufacturer shall include, in the operating and maintenance instructions, any restrictions, limitations, or special procedures for non-operating or out-of-service trampoline courts, and their associated components, which are exposed to wind.

3.1.5 Detail Design

3.1.5.1 A structural analysis shall be performed for each trampoline court to verify that there is adequate structural capability in the design.

3.1.5.2 The type of analysis selected shall be recognized and accepted engineering practice, in accordance with recognised Standards and shall be documented and available for third party verification.

3.1.5.3 The structural analyses performed shall consider and incorporate all significant loads and identify all significant stresses and strains that are anticipated to be experienced by the trampoline court.

3.1.5.4 The required strength of the structure and its elements shall be demonstrated both statically and dynamically using a minimum of five times the weight of an adult patron as per 3.1.3 i.e. 5 x 75KG.

3.1.5.5 Structures shall be analysed to verify that significant plastic deformation or collapse, or both, shall not occur under any loading condition that might be anticipated to occur a limited number of times during the operational life of the structure. Examples of such loading include environmental loads, patrons attempting to apply excessive (that is, abusive) loads, and extremely heavy patron weights.

3.1.5.6 A deflection analysis shall be performed if deformations in structural members or structural systems due to expected loading conditions could impair the serviceability of the structure.

3.1.5.7 The structural analysis for the trampoline court shall consider 'strength' and 'fatigue' as criteria in the evaluation of stresses resulting from the application of loads. The number of times that a specific load or combination of loads is expected to occur throughout the designated number of operational hours for the trampoline court shall determine whether the resulting stress levels will be limited by strength alone or strength and material fatigue limits. The method of analysis and load factors applied to specific loads shall be selected and based upon the number of times loads are expected to occur during the specified number of operational hours (that is, strength versus fatigue evaluation).

3.1.5.8 The yield and ultimate strengths and fatigue properties of the materials utilized for all components that could affect safety, upon failure of the component, shall be evaluated. Empirical testing, or empirical testing in combination with analysis, may be used as a means of evaluating the strength and fatigue properties of the materials for these components. If empirical testing is used for evaluation, the designer shall clearly specify and describe the testing procedure.

3.1.6 Drawings and Records:

3.1.6.1 The designer or manufacturer shall produce and retain applicable as-built drawings, calculations, and control software that describes the trampoline court or any major modification details. These drawings and calculations shall be retained for the design life of the equipment or whilst the equipment remains in operation, whichever is the longer time.

3.1.6.2 Documents deemed proprietary and confidential by the manufacturer shall include such a statement on each document. Use of the manufacturer's documentation and records should be limited, where possible, to the installation, maintenance, inspection, operation and design review of the trampoline court and arena. All other dissemination should be limited.

3.1.6.3 Documentation supplied to the buyer, owner, or operator shall be complete and adequate for proper installation, design and item registration where required, maintenance, inspection, and operation of the trampoline court or major modification of the unit.

3.1.6.4 Drawings and documents shall illustrate and define all important dimensions and tolerances. Dimensions, tolerances, and other important characteristics shall be clearly depicted in appropriate views and cross sections. The following shall be included:

- a) General drawings or diagrams in plan, elevation, and sectional views showing the general arrangement of components, including patron clearance envelope.
- b) Assembly and subassembly drawings providing additional views of areas not clearly discernible from the general drawings and providing clear identification and specification of all included components, their locations, and other information as applicable, e.g. correct adjustment(s) of adjustable equipment, fastener tightening specifications and descriptions of any other materials or lubricants used that are essential to the safe operation of the trampoline court.
- c) Detailed drawings of all components specifically manufactured for use in the trampoline court or as part of the major modification.

3.2 SAFETY REQUIREMENTS

3.2.1 Patron Containment:

3.2.1.1 Containment shall not be required within the assembly area(s) nor within dismount zones protected by impact attenuating materials in accordance with this Code of Practice.

3.2.1.2 The trampoline court shall be designed to support and contain the patron(s) within its perimeter during normal operation.

3.2.1.3 The surfaces with which patrons can come in contact shall be smooth and rounded, free from sharp, rough or splintered edges and corners, and have no protruding studs, bolts, screws or other projections with the potential to cause injury.

3.2.1.4 Adequate padding shall be provided where the usage of the device can cause patrons to fall or jump against the device. See also clause 3.3.7 regarding padding over springs.

3.2.1.5 Any system or systems used to support and contain the patron(s) shall be securely fixed to the structure of the trampoline court or an immediately adjacent structure and shall have adequate strength for the intended forces produced by the use of the trampoline court and the reasonably foreseeable actions of the patron(s).

3.2.2 Requirements for Patron Containment Systems (See Fig. 1)

[For performance trampolines refer clause 5.5.2]

3.2.2.1 The perimeter containment system shall be a minimum of 4100mm vertical height from the horizontal trampoline frame.

3.2.2.2 Angled trampoline frames with a slope of 90-135 degrees from the horizontal trampoline base frame shall be considered as a containment wall and included in the 4100mm vertical height calculation.

3.2.2.3 The minimum vertical height of a containment wall above an angled trampoline frame with a slope of 90-135 degrees from the horizontal trampoline base frame shall be 1500mm.

3.2.2.4 Angled trampoline frames with a slope of more than 135 degrees from the horizontal trampoline base frame shall be considered as part of the horizontal base frame.

3.2.2.5 When an immediately adjacent wall is used for patron containment, the distance between the trampoline frame and the wall shall not exceed 50mm. (Refer Fig 1a.)

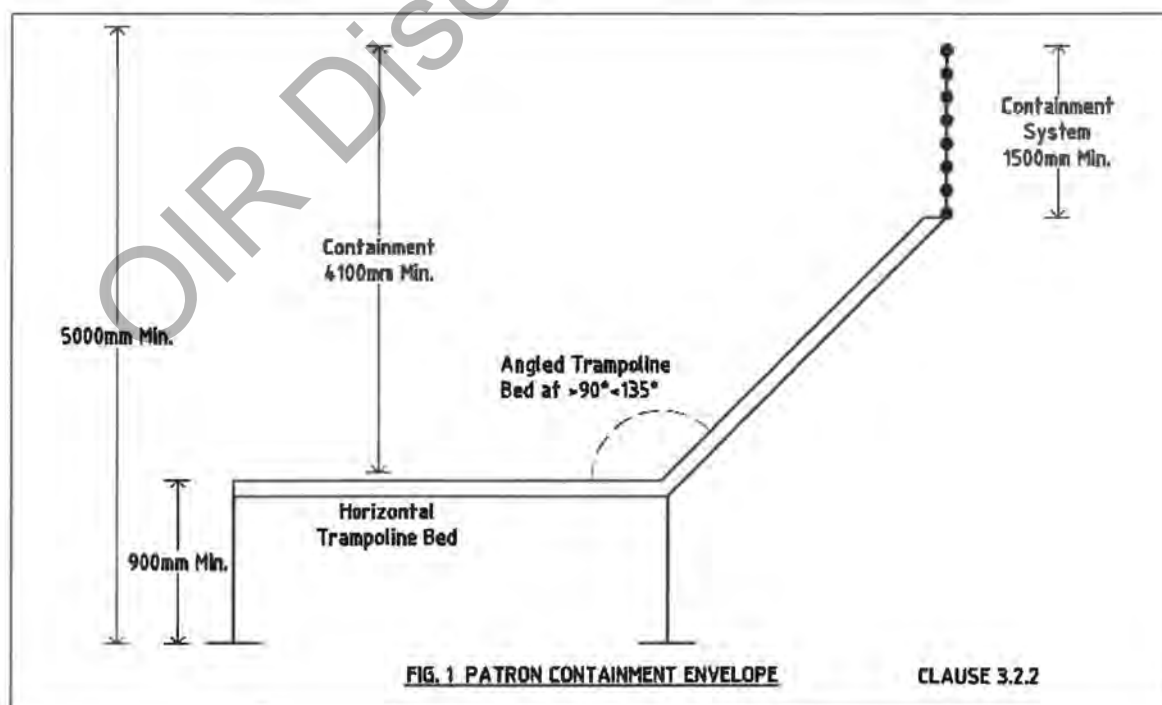

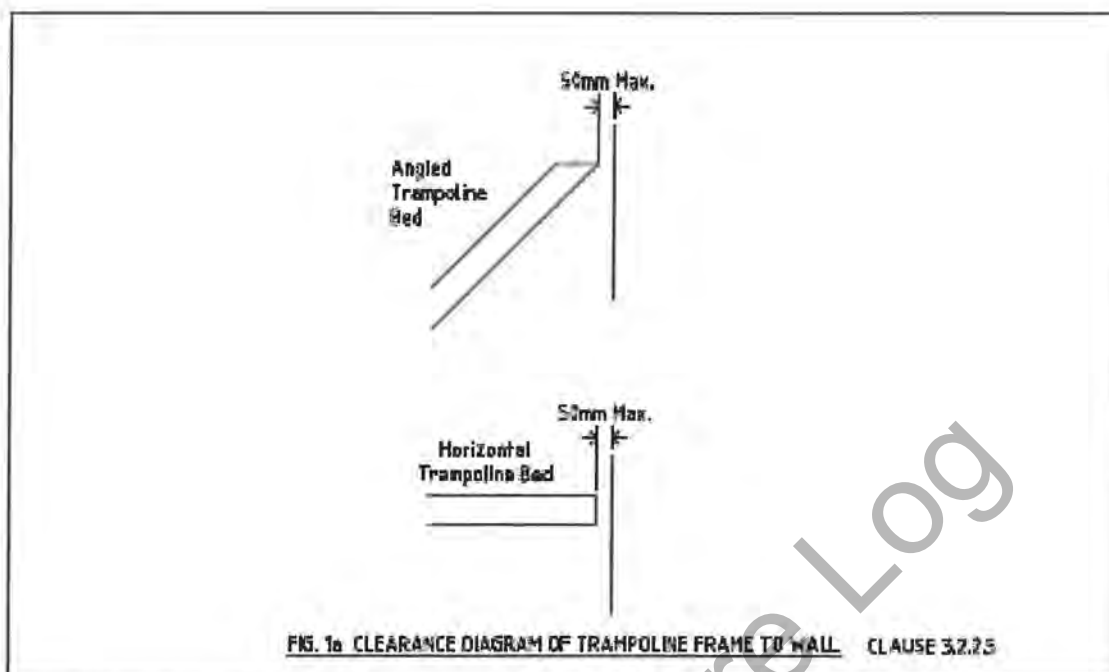

3.2.3 Netting

3.2.3.1 Netting used in trampoline parks shall either:

(a) comply with an Australian Standard and be accompanied by the manufacturer's product specification and test certificate; or

(b) where there is no appropriate Australian Standard, comply with an appropriate international Standard and be accompanied by a full description of the product, sufficient to eliminate any errors in its replacement, together with the manufacturer's test certificate.

3.2.3.2 Barrier/mesh netting systems shall comply with the requirements set out in Table A below.

3.2.3.3 Vertical barrier/mesh netting systems for perimeter containment or moveable park dividers shall meet the requirements for dividing curtains set out in Table A.

3.2.3.4 Netting installed as ball containment shall meet the requirements set out in Table A.

3.2.3.5 Netting installed as raised area separation shall meet the requirements set out in Table A.

3.2.3.6 Netting systems shall be installed, and maintained by visual inspection, to ensure that no hazards are created, or permitted to remain once identified.

3.2.3.7 Where netting is used to guide patrons from a trampoline into a foam pit, it shall extend from the edge of the foam pit at least half the length of the exiting trampoline or a minimum of 1000mm, whichever is the greater.

3.2.3.8 Barrier net/mesh systems shall be used underneath horizontal trampoline beds as a redundant fall barrier unless a documented hazard identification and risk assessment has been carried out by a competent person, and demonstrates an alternative method provides an outcome as safe as the redundant fall protection.

3.2.3.9 Barrier net/mesh systems shall be used behind angled trampoline beds as a barrier to entry. Refer Fig 6.

3.2.3.10 Netting material for structural purpose, containment or redundant fall protection used inside enclosed structures should be treated with flame retardants or be protected by an automatic water spray deluge system complying with AS 2118.3 that is activated by smoke or fire.

TABLE A
NETTING SPECIFICATION

Purpose	Dividing Curtains	Ball Containment	Raised Area Separation
Construction	Knotted, twisted 48 ply	Knotted, twisted	Knotted, braided
Material type	Polyethylene/HDPE	Polyethylene/HDPE	Polyethylene/HDPE
Mesh colour	Black	Black	Black
Mesh style	Square or rhomboidal	Square or rhomboidal	Square or rhomboidal
Mesh size	Maximum 40mm	Maximum 45mm	Maximum 100mm
Mesh diameter			3.0 mm
Basic Denier [+/-7%]	380	720	720
Mesh twine	Twisted	Twisted	Braided
Runnage MT/Kg [+/-8%]	432	337	300
Ply TPM [+/-10%]	185	165	
Breakstrain [Kg] min	68.5	90	100
Net weight kg/sq.m.	0.15	0.18	.084
Treatments	UV protected	UV protected	UV protected
	Low water absorption	Low water absorption	Low water absorption
	100% inert – no bacterial growth	100% inert – no bacterial growth	100% inert – no bacterial growth
Border rope	6mm double braided polyester	6mm double braided polyester	6mm double braided polyester

3.2.4 Dismount Surface:

3.2.4.1 Dismount surfaces incorporated into the design of a trampoline court shall be covered by impact attenuating materials as specified in this Code of Practice.

3.2.4.2 Dismount surfaces shall not be lower than 50mm below the trampoline horizontal frame.

3.2.4.3 Dismount surfaces shall not be higher than 1250 mm above the trampoline horizontal frame.

3.2.4.4 Performance walls are raised walls greater than 1250mm and less than 3500mm above trampoline bed height, and used for performance related trampoline activity. They must be positioned directly adjacent to the trampoline so as to leave no gap between the trampoline frame/padding and the wall. Padding immediately below the wall & surrounding all four sides of the trampoline must be at least 200mm thick over the frame & immediate horizontal hard surfaces for a minimum of 1500mm. Padding must be able to withstand a head crash attenuation test from a fall height of 4000mm. The padding over the springs or suspension system will be wide enough to completely cover the suspension system at rest, and from the frame edge, can be tapered to 50mm minimum at the trampoline bed edge. (i.e. tapered over the springs to reduce the height at the trampoline bed).

The top of the wall shall be a flat surface suitable for mount and dismount activities and have a minimum depth of 1000mm, unless padding of the surrounding containment is provided, in which case a depth of 900mm may be permitted. Any edge of the flat surface [top of wall] not intended for egress shall have barrier protection as required by Clauses 3.2.1 and 3.3.8 of this Code of Practice or BCA.

The wall shall be constructed to allow users egress

- a) towards the trampoline or
- b) by stairs or ladder complying with BCA requirements.

3.2.5 Impact Attenuating Material:

3.2.5.1 Materials used for impact attenuating [i.e. pad cover, frame padding, cover attachments, tie down(s), and pad seams used outdoors and subject to UV degradation] shall be made from ultraviolet (UV) resistant materials.

3.2.5.2 The impact absorbing system shall create a surface in the fall zone that shall not produce any impact that results in a g_{max} measurement greater than 200, a head injury criteria value greater than 1000 or an unacceptable impact profile when tested in accordance with Appendix "C" or an equivalent impact test. Four locations shall be tested on each specimen. Each impact test shall comprise four consecutive drops onto the same location on the specimen from a free height of fall 1500mm. Where the capability of the trampoline is greater than a standard poly bed with 5", 6", 7" or 8" springs, then the testing fall height should be increased beyond 1500mm in accordance with the capability of that trampoline e.g. a performance trampoline shall have a test height of 4000mm.

The manufacturer shall supply the specified impact absorbing material or shall ensure the designer's specifications are made available to the purchaser of the trampoline court and the obligation on the PCBU to install and use such material, as required under AS 3533.2, is noted within the operations manual.

3.2.5.3 Materials used in any impact attenuating material, pad cover, frame padding, cover attachments, tie down(s), and pad seams used inside enclosed structures shall be made from flame resistant materials that meet or exceed the requirements for Flame Resistance specified in this Code of Practice.

3.2.5.4 The frame padding shall cover the top surface of the frame, and be wide enough to completely cover the top surface of the suspension system including frame, springs and D rings at rest.

3.2.5.5 The impact attenuating materials shall be secured to the trampoline frame.

3.2.5.6 The padding shall be of a colour which contrasts with the colour of the trampoline bed.

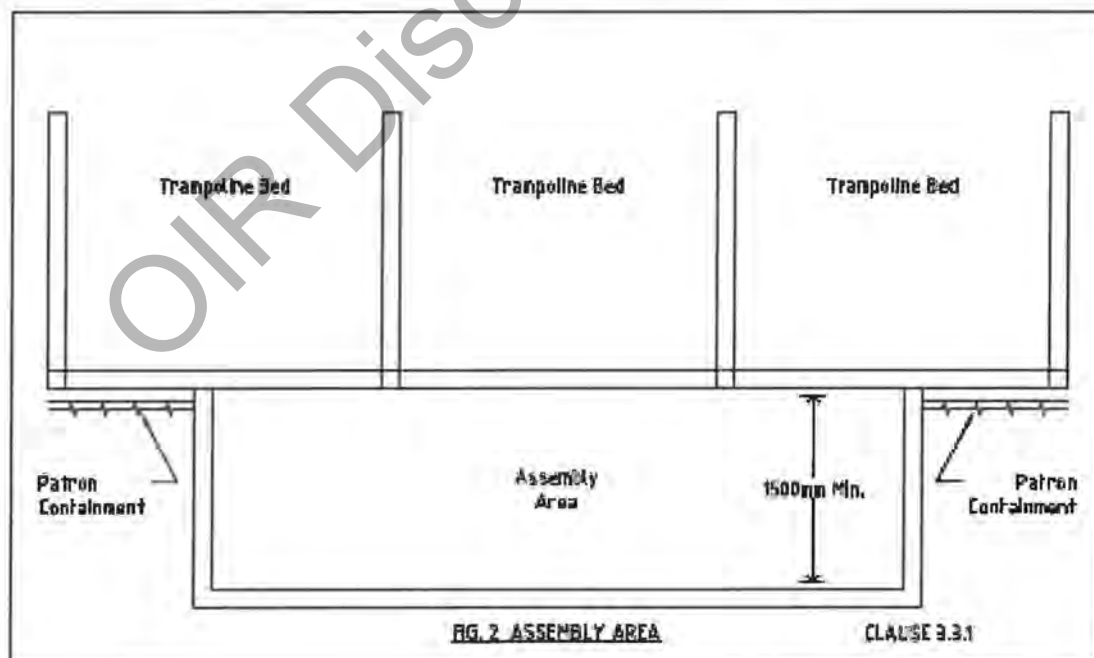

3.3 LAYOUT AND INSTALLATION

3.3.1 Assembly Area (See Fig. 2):

3.3.1.1 The assembly area shall be no more than 50 mm vertical above or below the top of the trampoline frame.

3.3.1.2 Barriers, fences, gates, hand rails, queue lines, seating, obstructions or platforms that border an assembly area shall be protected with impact attenuating materials in accordance with this Code of Practice.

3.3.1.3 Steps, ramps, barriers, queue lines or handrails that are installed within assembly areas or mount/dismount areas shall be protected with impact attenuating materials in accordance with this Code of Practice.

3.3.1.4 Assembly areas incorporated into the design of a trampoline park shall be covered by impact attenuating materials, as specified in this Code of Practice, within 1500 mm of the trampoline frame.

3.3.1.5 Accessibility to trampoline parks shall conform to requirements of the BCA allowing general access for disabled guests. Access to trampolines shall need to be determined on a case by case basis for each individual's capability to handle the action and forces resulting from use of the trampoline[s] without suffering personal injury.

3.3.1.6 Impact attenuating material shall be of a colour which contrasts with the colour of the floor or platform surface.

3.3.2 Obstructions:

3.3.2.1 Obstructions within the trampoline court, assembly area or within 1500 mm of the trampoline frame at points of egress from the trampoline court shall be guarded or covered with impact attenuating materials in accordance with this Code of Practice.

3.3.2.2 Emergency exit signs, strobe lights, alarm speakers, egress lighting required by BCA or local regulations shall be guarded to prevent any possible injury to patrons using the trampoline court.

3.3.2.3 Obstructions are not permitted within the patron clearance envelope.

Examples of obstructions not permitted include, but are not limited to, trusses, fire sprinkler systems, signage, lighting, and duct work and under the trampoline beds include, but are not limited to, the storage of equipment and consumables.

NOTE: Fittings related to the usage activity of the trampoline court may be permitted above the trampoline bed. e.g. harness equipment

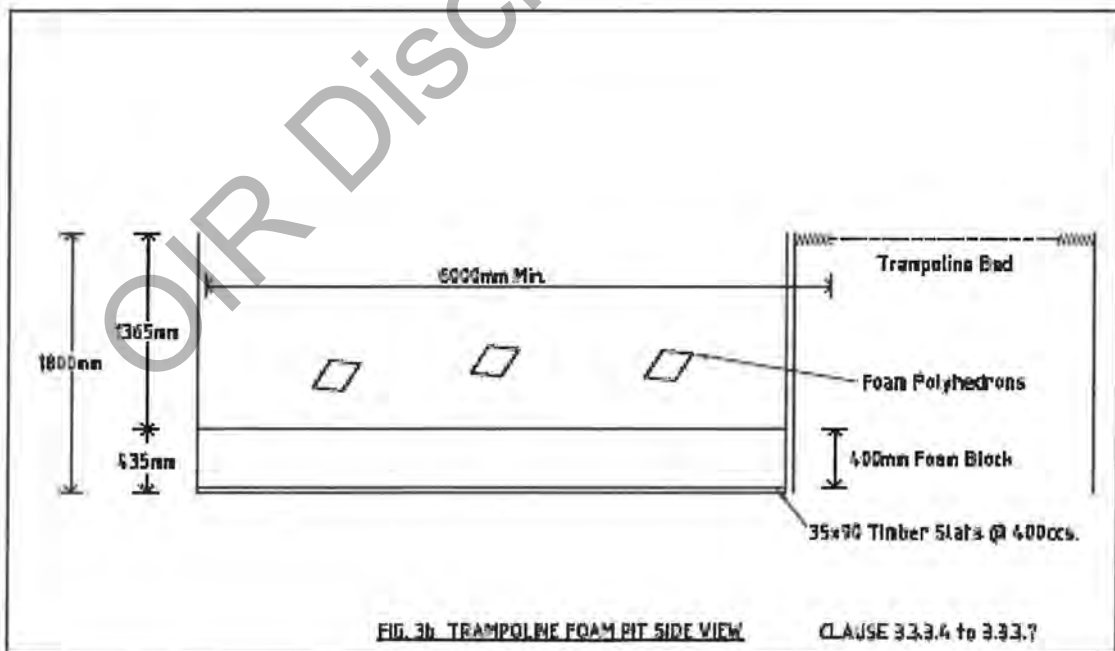
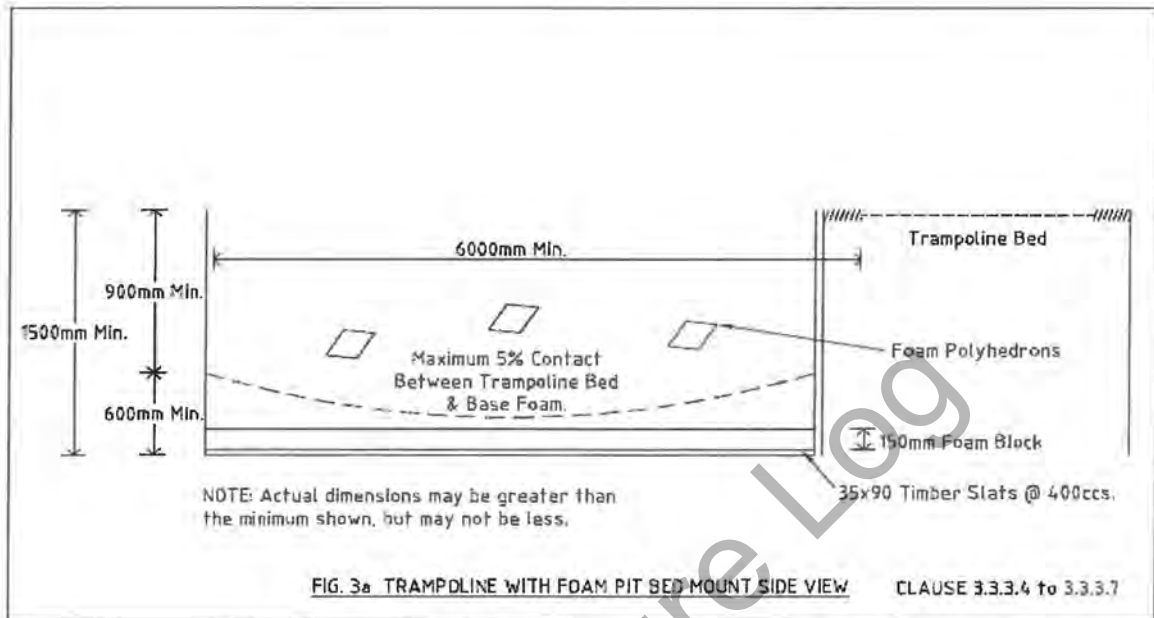

3.3.3 Trampoline Court Foam Pits (See Figs. 3a, 3b and 4):

3.3.3.1 Foam pits used for the purpose of dismounting from a trampoline court shall meet or exceed the following minimum specifications:

3.3.3.2 Length At least 6000 mm in length from the leading edge of the trampoline court bed prior to the addition of impact attenuating material

If multiple horizontal trampolines are positioned to allow dismount from various angles other than parallel, the minimum length shall be at least 6000mm from the angled trampoline bed frame in the direction of forward projection.

3.3.3.3 Width—At least 1500mm on each side of the trampoline bed prior to the addition of impact attenuating material unless an adequate method of patron containment is provided.

In addition:

- where multiple trampolines are positioned parallel to each other, then the distance between any two shall be at least 2400 mm from the centre of the trampoline beds, or
- where multiple horizontal trampolines are positioned to allow dismount from various angles other than parallel, the minimum width shall be at least 6000 mm

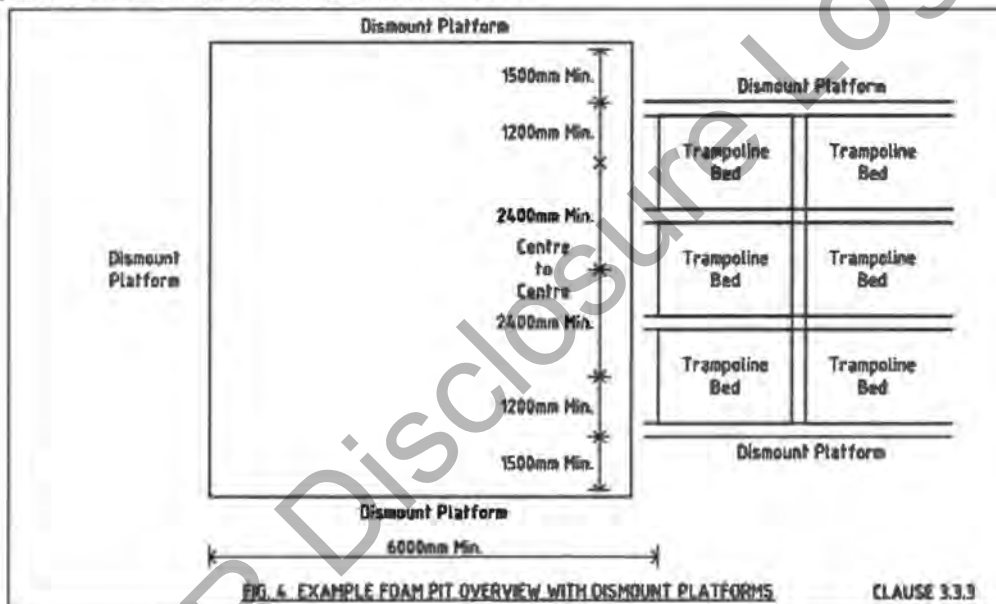

3.3.3.4 Depth

The minimum depth of a foam pit, measured from the base of the pit to the top of the trampoline frame, will vary depending on the style of cushioning utilised in the pit.

- A pit with no trampoline bed, but a foam base on timber slats, supporting foam polyhedrons, will be a minimum of 1800 mm deep
- A pit using a secondary trampoline or net system, supporting foam polyhedrons, will be a minimum 1500 mm deep
- A foam pit using angled trampolines for access will be a minimum of 1800 mm deep.
- A pit using an airbag will be a minimum of 1500 mm deep

The depth of the foam polyhedrons shall be no less than 1365 mm in pit type a); 1315 mm in pit type b) and 1615 in pit type c).

The foam pit design shall include an engineered fail safety system.

Examples include but not limited to:

- a unitary open-cell foam block, minimum 400 mm thick, supported on 90 x 35 timber slats at 400ccs to allow foam to breathe;
- a secondary trampoline at the base of the foam pit with a 150 mm thick foam block, supported on 90 x 35 timber slats at 400ccs to allow foam to breathe;

- iii. a combination of both these two features;
- iv. an impact attenuating air bag system, including a 400mm foam bed on 90x35mm timbers at 400ccs;
- v. other engineering designed fail-safe systems.

3.3.3.5 Foam pit Bed Mount The mounting device shall be positioned at least 600mm above the foam pit floor and at least 900 mm below the top of the trampoline frame.

Except if multiple horizontal trampolines are positioned to allow dismount from angled trampolines along the side of the foam pit, the mounting device shall be positioned at least 600 mm above the foam pit floor and at least 1200mm below the top of the trampoline frames. Refer Figs 5a & 5b.

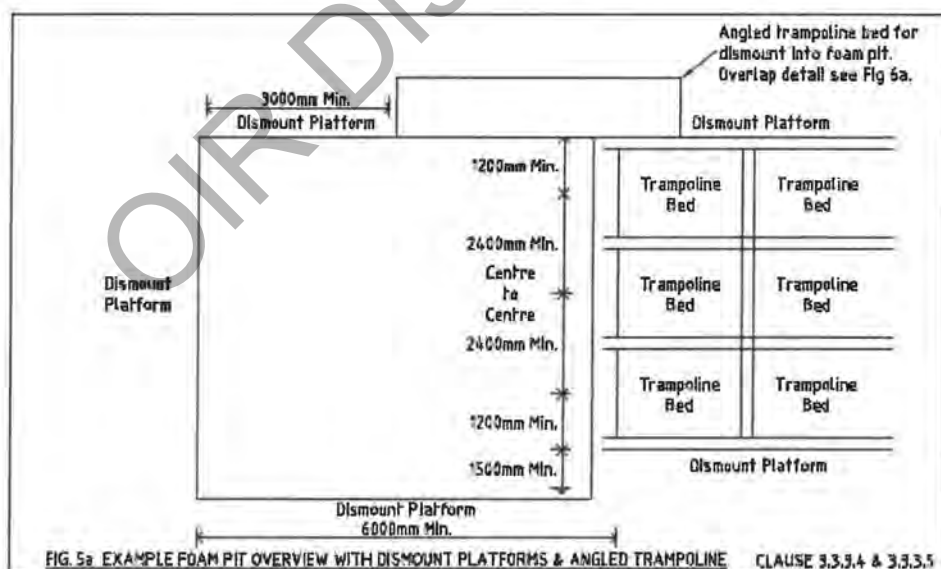
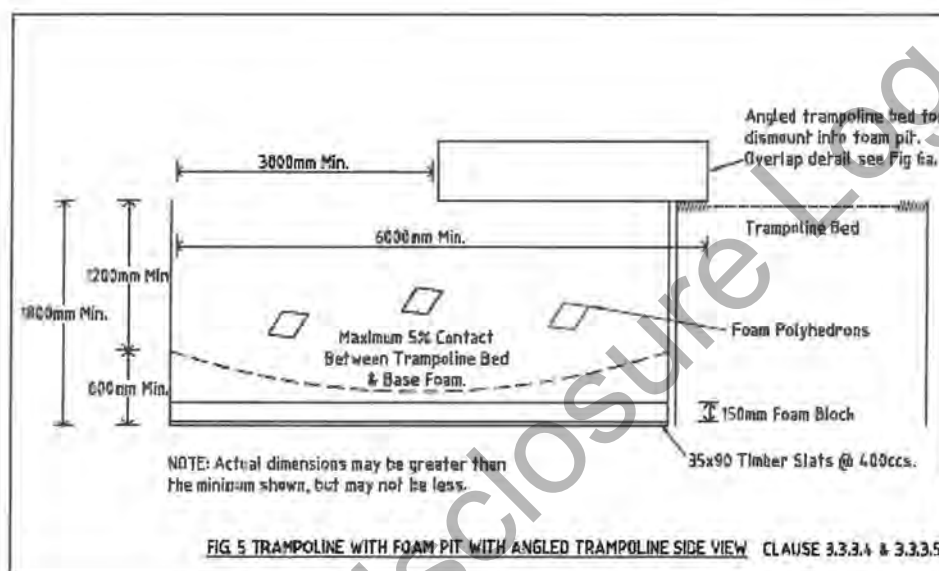

3.3.3.6 Bed Sag When the foam pit is filled with impact absorbing blocks and at rest, the trampoline bed incorporated into the design must be at least 185 mm above the foam pit floor at the lowest point.

3.3.3.7 Impact attenuating block material shall be installed underneath the trampoline bed incorporated into a foam pit as outlined in Clause 3.3.3.4 above. The block impact material shall not contact more than 5% of the total bed surface when the foam pit is filled with impact attenuating blocks and at rest.

3.3.3.8 Impact attenuating material shall cover all sides of the foam pit from the impact attenuating material to the top of the adjacent trampoline frame and all inside walls to a minimum of 800mm below the top of trampoline frame height, in accordance with the specifications in this Code of Practice.

3.3.3.9 If the side walls or back wall extend beyond the top of the trampoline frame, then the walls and top of walls shall be covered with impact attenuating material for an additional 1500mm above the trampoline frame, in accordance with the specifications in this Code of Practice.

NOTE: Netting or small mesh material need not be covered with impact attenuating material.

3.3.3.10 The side and back patron containment walls of a foam pit should be constructed of a smooth material or small mesh material system in accordance with manufacturer's specifications.

3.3.3.11 If there is a dismount platform adjacent to the foam pit, the dismount platform shall be covered with impact attenuating material in accordance with the specifications in this Code of Practice.

3.3.3.12 The foam pit may be surrounded by any combination of dismount platforms, horizontal trampolines, smooth walls or containment netting (See Figs. 4 and 5.) but any netting used to guide patrons from a trampoline into a foam pit shall extend from the edge of the foam pit at least half the length of the exiting trampoline or a minimum of 1000mm, whichever is the greater.

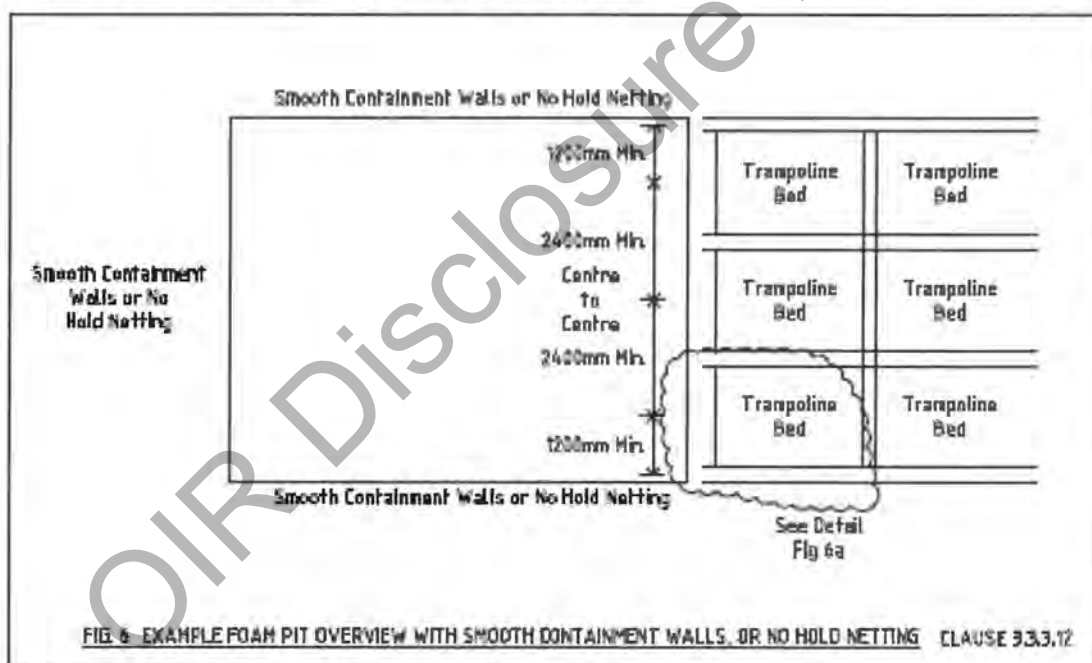

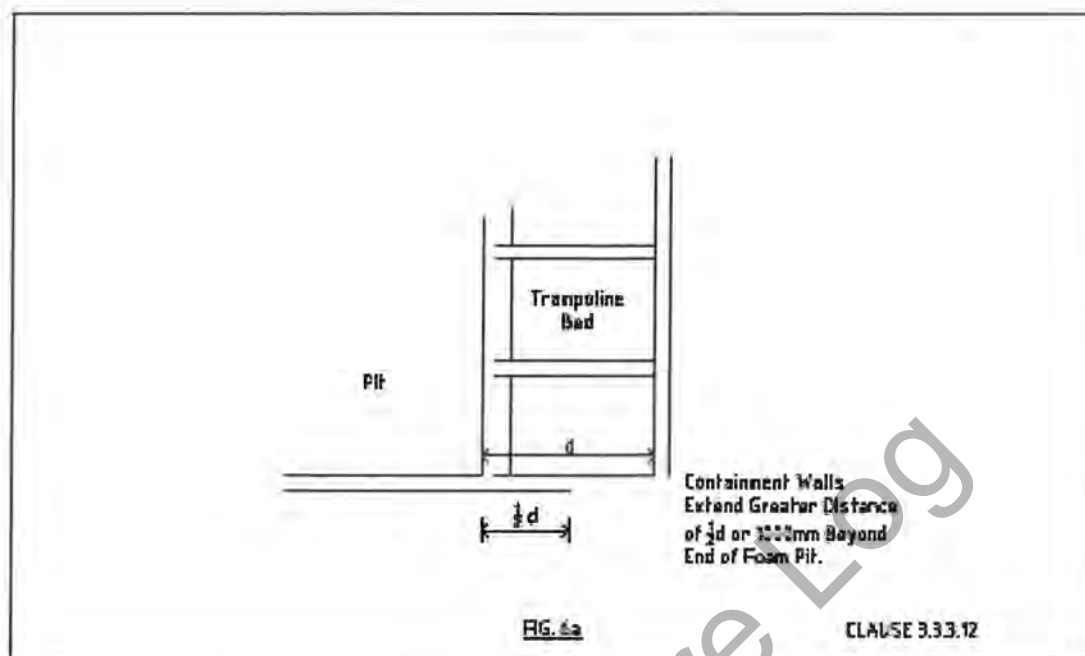

3.3.3.13 Foam used as impact attenuating loose fill material shall have a smallest edge of 150mm and may be any polyhedron shape.

3.3.3.14 The impact attenuating polyhedrons shall be made from flame retardant foam tested for compliance with a minimum rating of BS 5852 Source 2 or the foam pit may be fitted with an automatic water spray deluge system complying with AS 2118.3 that is activated by smoke or fire.

3.3.3.15 Impact attenuating foam material shall be classified for density as per AS 2282.3 and hardness as per AS 2282.8. Non flame retardant foam may be 23-130 Std grade and flame retardant foam may be 30-140 FR grade.

3.3.4 Inflatable bags as foam pit replacement

3.3.4.1 Airbag requirements:

Coated fabrics used in or attached to an inflatable device shall be tested in accordance with the surface ignition test (Procedure A) in ISO 15025 and shall comply with either of the pass criteria for flammability performance as specified in BS 3408:1992.

NOTE: BS 3408:1992 specifies test 2A of BS 5438 as the test method for determining the flammability of PVC-coated fabrics, however ISO 15025 has superseded this test method and is therefore specified.

A Warning System for Power failure (Whoop Box) and a warning system for fan failure which provides both a visual and audio signal shall be installed.

A free standing airbag shall have a skirt connection between the trampoline edge & the bag to prevent patrons falling between the two. The floor directly beneath the airbag will be padded with 400mm foam for fall protection, supported on 90 x 35 timber slats at 400ccs to allow foam to breathe.

Any exposed floor around the airbag will be protected to a width not less than 1500mm wider than the bag with 150mm thick foam mat.

A bag set in a pit or walled installation will have a skirt attached on each side to prevent patrons from falling between the bag edge & the wall, or between the wall & the trampoline edge.

A bag set in a combination of pit and/or wall and/or free standing will have padded floor beneath the bag of 400mm foam supported on 90 x 35 timber slats at 400ccs to allow foam to breathe.

A skirt attachment on each built-in side, including the trampoline side, and a padded perimeter to 1500mm width of 150mm thick foam on any open side with access to any exposed floor.

Dimensions

- Minimum height of airbag (not including base foam padding underneath): 1200mm
- Minimum height of containment pit where used shall be 1500mm
- Minimum length 6000 mm
- Width shall extend 1500mm from outside perimeter of trampoline mat unless within containment walls or no-hold netting as per Figs 5 & 5a.
- Minimum of 1 Air chamber per m² of pit floor area. i.e. If pit is 6 x 3 then air bag shall have a minimum of 18 air chambers,

3.3.4.2 Set-up requirements:

Padding underneath airbag shall be a minimum of 400mm thick foam

Padding on pit wall (L shaped) shall be a minimum 50mm thick.

Distance from edge of trampoline to side [1500mm] and straight forward [6000mm] unless smooth wall [see fig 4].

3.3.5 Trampoline Frame:

3.3.5.1 The trampoline shall be designed such that no part of the frame or legs can be contacted by the trampoline bed during normal operation.

3.3.5.2 Steel Elements— All exposed steel shall be inherently corrosion resistant or be provided with a corrosion resistant coating.

3.3.5.3 The frame system shall be able to withstand maximum permitted loads without permanent deformation of any elements in the system.

3.3.6 Trampoline Bed:

3.3.6.1 Normally, trampoline beds consisting of at least 95% polypropylene fibre content that meet the requirements of this Code of Practice for commercial use shall be used in the construction of trampoline parks.

NOTE: In special cases performance trampolines may be installed and their use controlled independently of other trampoline court trampolines.

These performance trampolines will comprise a trampoline bed of one of the following:

- i. a 2 or 4 string woven construction, or
- ii. a FIG approved web bedding of no less than 4mm width.

3.3.6.2 Trampoline beds designated by the manufacturer for consumer use only, residential use only, or home use only, but not for commercial use, (or equivalent designations), shall not be used in a trampoline park.

3.3.6.3 Height of the trampoline bed from the ground or floor shall be sufficient to prevent the bed from contacting the ground or floor during maximum load.

3.3.6.4 The minimum trampoline bed height shall be the calculated bed height based on the maximum user weight plus a 150mm factor of safety or a minimum of 900mm above the ground surface when the bed is at rest, whichever is greater. (See Fig. 1.)

Exception: Trampoline beds used as an element in a Foam Pit shall meet the minimum height in accordance with 3.3.3 Foam Pits of this Code of Practice.

NOTE: These beds are not designed for direct patron contact.

3.3.6.5 Trampoline beds shall be designed and manufactured to withstand maximum permitted loads without permanent deformation or breakage during normal operation.

3.3.6.6 Trampoline beds shall have a minimum tensile strength of 3600kPa warp and 3000 kPa fill [weft].

3.3.6.7 Trampoline beds shall have a minimum bursting strength of 5250 kPa.

3.3.6.8 Trampoline beds shall have minimum tear strength of 1300 kPa warp and 1150 kPa fill [weft].

3.3.6.9 Trampoline beds shall have minimum puncture strength of 1300 kPa.

3.3.6.10 The trampoline bed shall not allow more than 10 kilolitres of air per minute to pass through the material. This test does not apply to performance trampolines.

3.3.6.11 Trampoline beds used outdoors and subject to UV degradation must include U/V degradation inhibitors.

3.3.6.12 Trampoline beds shall not be arranged in a stepped or riser configuration, unless they have a minimum 1200mm horizontal spacing between trampoline frames.

3.3.6.13 The rated capacity of a trampoline court shall not exceed 1 participant per 5.6 m² based on the overall footprint of the trampoline court, excluding walls angled at 45 degrees or greater.

3.3.6.14 Footprint shall include but not be limited to: horizontal [or less than 45 degree inclination to the horizontal] trampoline beds, frames, rest areas, and dismount platforms.

3.3.7 Trampoline Suspension System:

3.3.7.1 The suspension system shall be designed so that the ends of springs or the ends of an alternate system do not present an impalement, pinch, scissor or slicing hazard.

3.3.7.2 The suspension system shall be covered with impact attenuating material in accordance with this Code of Practice or manufacturer's specification, whichever is the more stringent.

3.3.7.3 The impact attenuating material shall cover the entire top surface of the frame and be wide enough to completely cover the entire top surface of the suspension system at rest.

3.3.7.4 The impact attenuating material covering shall be a contrasting colour to the trampoline beds.

3.3.7.5 The manufacturer shall devise an impact attenuating & skirted system to prevent direct contact with the suspension system during normal operation. The impact attenuating system shall be designed to withstand direct impact of the user's body and not allow any limbs or fingers to penetrate into the suspension system. This clause does not apply to performance trampolines.

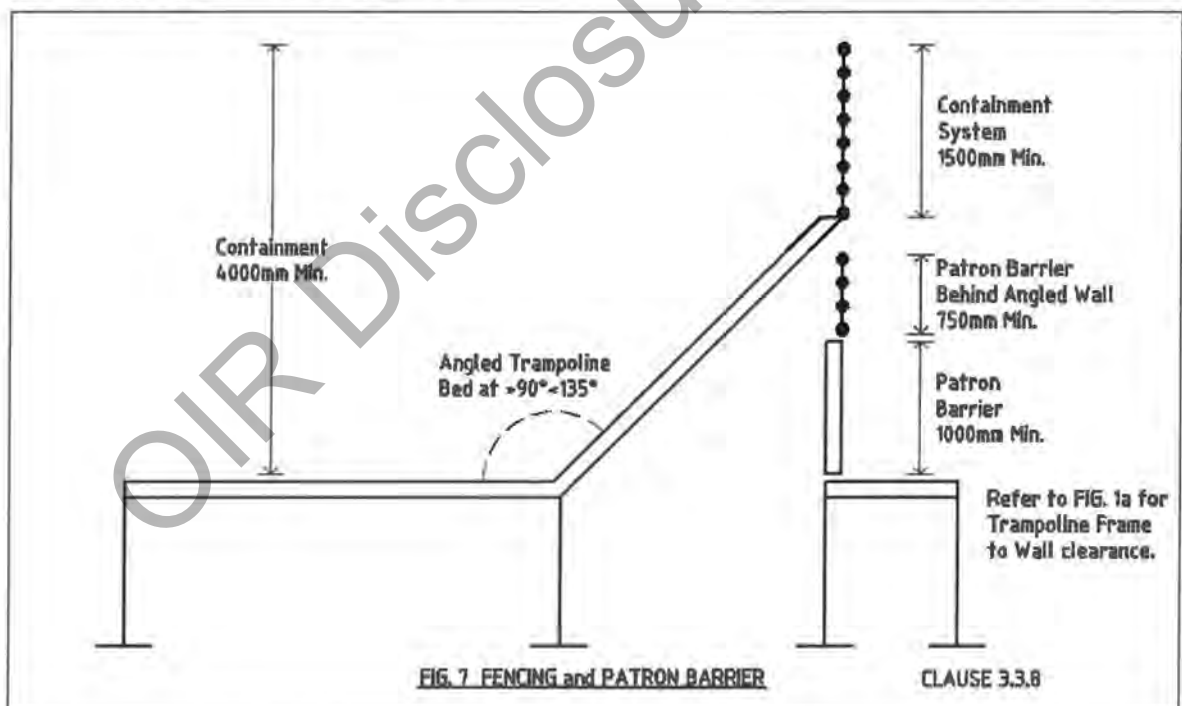

3.3.8 Patron Barriers (See Fig. 7):

Trampoline parks shall comply with AS 3533.1 2009 Fencing, Guardrails, Handrails, Gates, and Walkways for Amusement Rides and Devices.

3.3.8.1 For trampoline parks that feature an above grade suspension system, the accessible areas underneath the trampoline court shall have guarding in accordance with AS 3533.1 2009

3.3.8.2 Fencing or gates should not be positioned within the assembly area.

3.3.8.3 Barriers, fences and handrails should not protrude into a trampoline court or cause a hazard during access or egress.

3.3.9 Installation

3.3.9.1 All components shall be installed as per designer and manufacturer specifications.

3.3.9.2 The installer shall verify that all components and equipment are functioning to the designer and manufacturer specifications.

3.3.9.3 Self-locking nuts shall fully engage with the bolt.

3.3.9.4 Hardware in moving joints shall be secured against unintentional loosening.

3.3.9.5 There shall be no accessible sharp points or edges on fasteners.

3.3.9.6 There shall be no accessible burrs, sharp points, or sharp edges on frames.

3.3.9.7 The trampoline court shall be designed, built and installed such that no part of the frame, legs or ground can be contacted by the bed while a patron is using the trampoline under normal operation.

3.3.9.8 The designer, manufacturer, constructor or installer of the trampoline court shall provide to the owner/operator clear and concise inspection, maintenance, and repair instructions, including, but not limited to, what, when, and how to inspect, maintain, and repair all components and equipment.

3.3.10 Fans:

Ceiling mounted fans and fans located within the trampoline court perimeter

- a) shall be guarded where contact with the fan blades or other moving components, by patrons, is possible.
- b) shall be installed in accordance with AS/NZS 3000.

3.3.11 Electrical:

3.3.11.1 Electrical systems for permanent trampoline parks shall be installed in accordance with AS/NZS 3000. Electrical systems for portable trampoline parks shall be installed in accordance with AS/NZS 3000 or AS/NZS 3002.

3.3.11.2 In addition to any requirements in the above Standards to provide protection to light globes and fittings, action shall be taken to ensure that damaged or broken lights or fittings cannot fall onto patrons even if struck by objects being used on the trampoline court. This requirement is stipulated in WHS or OH&S Regulations.

3.3.12 SUSPENSION ROPES AND CHAINS

3.3.12.1 Wire ropes used in trampoline parks shall either—

(a) comply with AS 1394 and AS 3569 and be accompanied by the manufacturer's product specification and test certificate; or

(b) where there is no appropriate Australian Standard, comply with an appropriate international Standard and be accompanied by a full description of the product, sufficient to eliminate any errors in its replacement, together with the manufacturer's test certificate.

3.3.12.2 Link chains used in trampoline parks shall—

(i) comply with AS 2321 and be accompanied by a product specification and test certificate;

(ii) where there is no appropriate Australian Standard, comply with an appropriate international Standard and be accompanied by a full description of the product, sufficient to eliminate any errors in its replacement, together with the manufacturer's test certificate; or

(iii) where a test certificate according to an Australian Standard or international Standard is not available for a link chain product, sufficient samples of the chain shall be tested to destruction to check that any batch used in construction or refurbishment of an amusement ride or device has the required characteristics. Proof documentation derived from this process shall be kept in the log for the ride or device for the period that any of the chain remains within the ride or device.

3.3.12.3 Wire ropes and chains shall be fitted and connected so that no connection or component shall have a load capacity less than that of the wire rope or chain with which it is associated.

3.3.12.4 Split or open link chains shall not be used.

3.3.12.5 Splicing of wire rope shall be carried out in accordance with AS 2759.

NOTE: AS 2759 also contains guidance on the selection of wire ropes for various applications, and should be consulted whenever wire ropes are used as part of an amusement device.

3.3.12.6 Rope (Includes, but not limited to Fibre, Synthetic, Rope, Line and eTP.):

a) The strength and application of rope, when used, shall be determined by the designer by applying standard structural engineering practice for expected dynamic, live and dead loads and uses materials that are applicable for the intended use.

b) Rope and rope accessories which directly support the load of a TP bed shall have a minimum safety factor of five.

c) The designer shall consider during the device analysis, the effects of the environment and wear on the primary load path materials, including but not limited to ultra-violet light, heat, and vermin.

3.3.13 Welding:

Welding of structural elements in trampoline parks shall either—

- (a) comply with AS 1554 series of standards for the design of the weld and the weld procedure and be accompanied by the manufacturer's product specification and non-destructive test certificate; or
- (b) where there is no appropriate Australian Standard, comply with an appropriate international Standard and be accompanied by a full description of the product, sufficient to eliminate any errors in its replacement, together with the manufacturer's non-destructive test certificate.

3.3.14 Metal Structures:

Suitability of Materials—Only metals and metal alloys for which industry recognized data are available, indicating the physical capabilities including endurance limit or fatigue S/N curve, shall be used for structural elements in trampoline parks.

3.3.15 Bolted Connections:**3.3.15.1 General**

The type of joint, based on its mode of load carrying (shear, tensile or combined), shall be determined, together with the magnitude of live and dead loads applicable to the joint.

Guidelines and design methods provided in AS 4100 and AS 3990 should be used as appropriate. In addition, the requirements and guidelines in Clauses 2.6.3.2 to 2.6.3.8 shall be taken into account in the design of dynamically active joints (joints subject to cyclic service loads).

Whenever practical, bolted joints should be designed to act in shear.

An appropriate locking device should be considered to prevent vibration loosening.

NOTE: If the bolt pre-tension is less than 65% of the proof load, under certain vibration conditions it has the potential to loosen. This potential may be minimized by tightening the bolt in excess of 65% of the proof load provided the bolt has enough capacity left to carry the service loads.

Stress concentration due to threads should be considered when carrying out a fatigue analysis.

3.3.15.2 Shear joints

If the maximum design tensile load on the bolt is less than 8% of the ultimate tensile load or the maximum design shear load on the bolt is greater than six times the maximum design tension load on the bolt, the bolted joint shall be considered a shear joint.

Shear joints should be designed as follows:

- (a) A shear joint where the live shear stress on the bolt is more than 15% of the proof shear stress of the bolt should be designed as a friction grip joint (TF) as per AS 4100.
- (b) If the shear joint needs to be regularly assembled and disassembled, it should not be designed as a TF or TB joint in accordance with AS 4100 unless the bolts are discarded at each disassembly.
- (c) Where the live shear stress on a bolt is less than 15% of the proof shear stress of the bolt, the joint may be designed as a shear (pin) or tension bearing joint (S or TB as per AS 4100).*

NOTE: An S-type joint may require an appropriate thread-locking device if it has the potential for vibration loosening.

3.3.15.3 Tensile joints

If the maximum design tensile stress (dead plus live) on the bolt is greater than 30% of the ultimate tensile stress of the bolt, the joint shall be considered a tensile joint.

Tensile joints should be designed as follows:

- (a) A tensile joint should be designed in such a way that the clamping force between the two joining members always remains positive during the life of the joint, taking into consideration the effects of bolt and joint stiffness. The bolt should not yield under the service loads experienced during the life of the joint.
- (b) If the peak live component of the maximum design tensile stress is greater than 30% of the ultimate tensile stress of the bolt, a fatigue analysis taking into consideration the effects of the joint and the bolt stiffness should be carried out.

{* FERNANDO, S. On the design and failure of high tensile bolt group joints subject to dynamic loading—Theoretical and experimental investigations, Case studies. Proceedings of International Conference on Failure Analysis and Maintenance Technologies (ICFAMT). Brisbane, Australia. April, 2004.}

- (c) If the maximum design tensile stress (live plus dead) on a bolt in the joint is greater than 30% of the ultimate tensile stress (UTS) of the bolt, a fatigue analysis taking into consideration the effects of the joint and the bolt stiffness should be carried out.

3.3.15.4 Combined shear and tensile joints

Joints not belonging to either shear joint or tensile joint classifications are classified as combined shear and tensile joints. Joints requiring regular assembly and disassembly belong in this classification.

Combined shear and tensile joints should be designed as follows:

- (a) Combined shear and tensile joints should be designed as friction grip joints if the live maximum shear stress (using Mohr's Circle) on a bolt due to combined design shear and tensile load action (dead plus live) is more than 15% of the proof shear stress of the bolt with a target pre-tension of not less than 65% proof load of the bolt.
- (b) Combined shear and tensile joints should be designed so the clamping force between two joining members always remains positive during the life of the joint taking into consideration the effects of bolt and joint stiffness. The bolt should not yield under the service loads experienced during the life of the joint.
- (c) A fatigue analysis taking into consideration the effects of the joint and the bolt stiffness should be carried out—
 - (i) if the peak live component of the maximum design principal (tensile) stress (using Mohr's Circle) on a bolt due to combined design shear and tensile live load action is greater than 40% of the total maximum design principal (tensile) stress (dead plus live); or
 - (ii) if the total maximum design principal (tensile) stress (using Mohr's Circle) on a bolt due to combined design shear and tensile dead and live load action is greater than 40% of the ultimate tensile stress of the bolt.

3.3.15.5 Use of dissimilar materials

The following requirements shall be applied:

- (a) Joint designs that require tightening of dissimilar materials and flexible or softer materials shall be given special consideration.
- (b) Effects of thermal loads shall be considered if the joint materials have different thermal expansion coefficients.
- (c) A stiffness-based joint analysis shall be performed in the design of safety-critical joints of this type.

3.3.15.6 Prevention against loosening

The design of the joint should minimize the need to use thread-locking devices.

If the joint has a potential to loosen then an appropriate thread-locking device shall be used.

The designer shall fully specify the identification, compliance and re-usability of thread-locking devices, especially for thread-locking devices to be used in joints that are to be regularly assembled and disassembled. Safety-critical pin-type joints formed by a bolt and nut shall be provided with a secondary means to prevent the joint from coming apart.

3.3.15.7 Stress corrosion cracking

Bolts that are subject to stress corrosion cracking (SCC), such as high tensile bolts (Class 10.9 and higher) and stainless steel bolts, shall only be specified for use after consideration of their susceptibility to SCC and the potential in the design for exposure to conditions that can cause SCC. The designer or manufacturer shall provide a diagrammatic scheme of the bolts in the device that are subject to SCC risks, together with details of a regular replacement program.

3.3.15.8 Complete specifications

The manual shall contain complete specifications for bolted joints and their components, covering the relevant topics in the following list:

- (a) The designer shall fully specify the details of the type of bolt, washer and nut (with reference to relevant standards), required finish, design pre-tension and the acceptable window of working pre-tension.
- (b) In addition, the method of achieving the desired design pre-load shall be provided. If tightening to a particular torque is the method of tightening, the relevant torque value and associated conditions (e.g. finish, coating, lubrication level (dry or oiled) or use of anti-seize) shall be specified.
- (c) The type and details of locking devices, where used, shall be specified, including the necessary frequency of replacement.
- (d) For multiple bolt group joints, the tightening sequence and steps shall be specified.
- (e) Advice that compliance certificates be obtained for any replacement bolts or bolt parts.

3.4 STATEMENT OF COMPLIANCE WITH CODE OF PRACTICE BY COMPETENT PERSON

Upon construction of a trampoline park, and prior to opening to the public, and then on an ongoing annual basis, a competent person shall be retained to prepare a Statement of Compliance of each trampoline park with the requirements of this Code of Practice. This Statement shall be displayed in a prominently visible position, accessible to the public, and shall include, but not be restricted to, information listed below.

All such information shall, to enable verification, be able to be supported by documentation held by the Proprietor and contained, where appropriate, in the operating and maintenance instructions for the installation.

DATE OF MANUFACTURE

STANDARD(S) TO WHICH DESIGN COMPLIES

DATE OF COMPLIANCE INSPECTION

DATE OF NEXT COMPLIANCE INSPECTION

NAME OF PERSON/ORGANISATION VERIFYING COMPLIANCE

Retrospectivity.

Trampoline courts existing at 30 June 2014 shall comply with the requirement for an annual statement by a competent person, although compliance with this Code of Practice (for structural design) will not be mandatory for these pre-existing venues.

3.5 INFORMATION TO BE PROVIDED BY THE MANUFACTURER OR SUPPLIER OF NETTING and IMPACT ATTENUATING MATERIAL

The following instructions outline requirements under AS 3533.1 2009 and AS 3533.2 2009 as applicable to trampoline parks. The designer, manufacture, supplier, or installer shall supply to the owner, operator, purchaser or requesting regulatory authority prior to shipment, or immediately after installation, as appropriate, the following certifications:

3.5.1 Containment Net, Safety Net or Small Mesh Material:

3.5.1.1 Certification that containment netting, safety netting or small mesh material meets the requirements specified in this Code of Practice.

3.5.1.2 Certification that containment netting, safety netting or small mesh material used inside enclosed structures meets the requirements for Flame Retardation specified in this Code of Practice.

3.5.1.3 Certification that containment netting, safety netting or small mesh material is installed in accordance with Manufacturer's specifications.

3.5.1.4 Certification that containment netting, safety netting or small mesh material used outdoors and subject to UV degradation, has been treated with UV degradation inhibitors and a representative sample has been tested and was found to be in accordance with this Code of Practice.

3.5.1.5 Certification that containment netting, safety netting or small mesh material contains no more than 100 ppm of lead.

3.5.2 Impact Attenuating Material:

3.5.2.1 Certification that impact attenuating material and covering material used inside enclosed structures meets the requirements for Flame Retardation specified in this Code of Practice.

3.5.2.2 Certification that impact attenuating material meets the performance criteria of this Code of Practice as specified in Clauses 3.2.4.4 and 3.2.5.2.

3.5.2.3 Certification that impact attenuating material and covering material contains no more than 100 ppm of lead.

3.5.3 Trampoline Bed:

- 3.5.3.1 Certification that the trampoline bed meets or exceeds the minimum requirements for puncture strength, tear strength, tensile strength, bursting strength, and air flow as set out in this Code of Practice.
- 3.5.2.2 Certification that trampoline beds to be used outdoors and subject to UV degradation have been treated with UV degradation inhibitors and a representative sample has been tested and was found in accordance with this Code of Practice.
- 3.5.2.3 Certification that the bed contains no more than 100 ppm of lead.

3.5.4 Trampoline Court:

- 3.5.4.1 Certification that the trampoline court's design, quality, manufacturer, construction and installation are in conformance with AS 3533.1 2009 and AS 3533.2 2009 and this Code of Practice.
- 3.5.2.4 Upon completion of the trampoline court, and prior to allowing access by the general public, the manufacturer, manufacturer's authorized representative, or third party inspector contracted by the manufacturer shall inspect all components of the court for conformity with manufacturer's specifications using an inspection criteria developed by the manufacturer, and issue a certificate of inspection to the owners of the trampoline court.

3.5.5 Foam Pit:

- 3.5.5.1 Certification that the foam pit design, quality, manufacturer, construction and installation are in conformance with AS 3533.1 2009 and AS 3533.2 2009, and the requirements of this Code of Practice.
- 3.5.5.2 Certification that the impact attenuating block material meets the requirements for flame retardation in accordance with this Code of Practice.
- 3.5.5.3 Certification that the impact attenuating block material meets the performance criteria of this Code of Practice.
- 3.5.5.4 Certification that impact attenuating block material contains no more than 100 ppm of lead.

SECTION 4 SPECIFIC TRAMPOLINE EQUIPMENT REQUIREMENTS**4.1 Moveable devices****Stability:**

- a) Portable trampoline courts shall be designed such that when erected and operated in accordance with the designer provided written instructions, the portable trampoline court will be adequately stable and resistant to overturning. The designer shall take into consideration all worst case loading (for example, unbalanced loading, wind loading).
- b) Within the manufacturer-provided written inspection instructions, the manufacturer shall specify how the stability of the portable trampoline court can be visually checked for acceptable settlement and level. This specific inspection instruction shall be specified to be performed:
 - (i) after erection is completed and
 - (ii) prior to the daily start of operation of the portable trampoline court.

This written inspection instruction shall describe how these measurements are to be assessed including the maximum amount of settlement and the maximum out-of-level tolerance allowable for trampoline court operation.

4.2 Moveable Systems:

- a) Any moveable system or device designed to temporarily encroach on the patron clearance envelope, that is, loading/unloading platforms, ramps, decks, or other devices, shall be designed in a fail-safe manner in order to prevent unintended contact.
- b) Moveable systems incorporated into the design of a trampoline court and stored within the patron containment envelope shall be protected by impact attenuating materials as specified in this Code of Practice.

4.3 Inflatable Devices:

Inflatable amusement devices or inflatable impact absorbing systems that allow dismount from a trampoline court, or inflatable amusement devices that have incorporated a trampoline suspension system into the design of the inflatable amusement device, shall meet the applicable requirements for a challenge game as specified in AS3533.4.1

4.4 Prohibited Devices:

Trampoline rebound devices designated by the manufacturer for consumer use only, residential use only, or home use only, but not for commercial use, or equivalent designation, shall not be used in a trampoline park.

4.5 Major Modification

Major modifications shall not occur without written approval from the manufacturer. In the event the manufacturer does not provide written approval for a major modification, the owner/operator may retain a different manufacturer or designer to complete or approve the major modification, or both.

Any such modification shall be required to comply with this Code of Practice even if the trampoline park was originally completed prior to the industry acceptance of this Code of Practice.

OIR Disclosure Log

SECTION 5 OPERATION

5.1 GENERAL

Trampoline park operators who claim they are complying with this Code of Practice shall meet all applicable requirements specified in the Code of Practice. They shall keep such essential records as are necessary to document any claim that the requirements within this Code of Practice have been met.

5.2 OWNER/OPERATOR [PCBU] RESPONSIBILITIES

Each owner/operator shall have written procedures for the trampoline park, which are an integral part of their staff-training program. These procedures shall include but not be limited to:

- 5.2.1 Specific trampoline park operation policies and procedures with pertinent information from the manufacturer's instructions including operational and maintenance instructions and requirements.
- 5.2.2 Established time interval for operation of each trampoline court.
- 5.2.3 Established communication system between court attendants if the trampoline court is staffed by two or more court attendants.
- 5.2.4 Procedures for limiting the number of patrons in the assembly area as required by the manufacturer and owners specifications.
- 5.2.5 Signage shall be placed by the owner/operator as specified AS 3533.2 2009 Clause 2.2.13. These signs shall include safety, warning, and instructional signage reflecting manufacturer recommendations. Signage shall be prominently displayed adjacent to the assembly area(s) or other appropriate area, or both.

The manufacturer may make recommendations for appropriate advisory signs or warning signs based on the design of the trampoline court. These recommendations should be clear and concise, but final responsibility for signage remains with the owner/operator.

The information on such signs should include the following:

- (a) The minimum or maximum allowable age or weight of patrons.
- (b) Advice that physical capabilities may be required that demand limb use or body control.
- (c) Advice for patrons who are pregnant, have medical conditions or are under medication.
- (d) Advice for patrons under the influence of alcohol or drugs.
- (e) Any other specific advice about the safe operation of the device, e.g. loose articles.
- (g) Participation could result in injury or death.

Emergency exit signs shall comply with the requirements of Clause 5.2.7.

As Patrons will not normally have access to this Code of Practice, then rules specifying Patron Responsibility shall be displayed within the public areas of the trampoline park premises or mobile trampoline park site. See details in Clause 5.7.

5.2.6 Evacuation plan

A comprehensive emergency plan shall be developed, practiced and maintained in accordance with occupational health and safety requirements or organizational policy guidelines, as applicable.

When developing the fire evacuation component of the plan, the assessment carried out in Clause 3.1.1(c) shall be taken into consideration.

Support personnel shall be trained in this procedure and trial evacuations held at appropriate intervals. The times and attendances at these trials shall be recorded.

5.2.7 Emergency lighting

Emergency lighting shall be used and illuminated exit signs deployed, except where natural light during power failure would be adequate. Such emergency lighting shall be inspected and maintained in accordance with AS/NZS 2293.2. Where the nature of the construction prevents the use of internally illuminated exit signs (e.g. light fabric walls), painted signs illuminated by general and emergency lighting may be used.

In addition, the following requirements shall apply:

(i) Where the emergency power is not generated by a self-contained power source within the device, an emergency generator or central battery system shall be used.

(ii) The emergency lighting and exit sign system shall be tested on a regular basis. For mobile trampoline parks, this testing shall take place each time the device is set up and prior to daily operation.

5.3 STAFFING

- 5.3.1 The owner of a trampoline park shall provide the appropriate number of court attendants, according to a minimum specified by the manufacturer or this Code of Practice, whichever is the greater, to effectively manage and monitor activities on the trampoline court or courts during operations.
- 5.3.2 In deciding how many court attendants are required, the operator shall consider factors including but not limited to the following:
- The manufacturer's recommendations or requirements,
 - The number of patrons using the trampoline court[s],
 - The age of patrons using the trampoline court[s],
 - The environment in which the trampoline park is located.
- 5.3.3 The minimum number of court attendants for a trampoline court in operation shall be no less than one.
- 5.3.4 The ratio of court attendants to active participants within the arena shall be not less than 1: 20 at any time the trampoline park is in operation, excluding patrons within the assembly area or patrons located in designated rest areas.
- 5.3.5 Court attendants shall monitor activity on the trampoline court at all times during operation.
- 5.3.6 Court attendants shall use approved devices or signal equipment to control and direct patrons and take appropriate action at the first sign of misbehaviour or violation of posted rules.

5.4 STAFF TRAINING

- 5.4.1 The owner of the trampoline park shall verify and document that court attendants receive training for their required duties in accordance with this Code of Practice.
- 5.4.2 At least two staff members on duty shall be qualified to Level 2 in first aid.

5.5 FACILITY OPERATION

5.5.1 GENERAL

- 5.5.1.1 The assembly area should be kept clear of onlookers and spectators. Only staff actively engaged in monitoring activity or patrons preparing to mount or having dismounted the trampoline court should be in the assembly area. This allows the court attendant[s] to have a clear view and allows patrons to mount and dismount safely from the trampoline court.
- 5.5.1.2 Patrons shall not be allowed to climb or hang on the walls or netting of a trampoline court unless the net or wall is designed for that activity.
- 5.5.1.3 Patrons who are not active participants shall not be allowed to sit or rest on trampoline beds, impact attenuating material surfaces, on dismount platforms, or within assembly areas.
- 5.5.1.4 Active participants are allowed to sit or rest within designated rest areas.
- 5.5.1.5 Court attendants shall monitor usage and ensure that the trampoline court is not overloaded with patrons, in accordance with the maximum usage numbers of both manufacturer's and owner's specifications. Where these differ, the lower of the two shall be used.
- 5.5.1.6 The owner or operator of a portable trampoline park shall ensure the device is installed as per manufacturer's specifications prior to operation and shall not operate the device if hazards exist. (See checklist requirements in clause 4.1 b).
- 5.5.1.7 Objects shall not be stored underneath or adjacent to trampoline beds that can interfere with the suspension system or movement of the trampoline bed.
- 5.5.1.8 The owner/operator of a trampoline park may deny entry to the arena to any person, if in the opinion of the owner/operator entry may cause above normal exposure to risk of discomfort or injury to the person who desires to enter, or if in the opinion of the owner/operator entry may jeopardize the safety of other patrons or employees.
- 5.5.1.9 Trampoline court attendants should be given guide-lines, related to the particular device they are supervising, and any special considerations concerning patron size and patrons with physical or mental disabilities or impairments.

5.5.2 HIGH PERFORMANCE TRAMPOLINES

The following independent controls shall be in place when high performance trampolines as referred to in Clause 3.3.6.1 are in use:

- The clearance envelope shown in Fig 8 shall be in place.
- The number of patrons allowed into the performance area shall be limited by the operator in accordance with facility policy.
- Only one patron at any one time shall be permitted on a performance trampoline.
Note: A qualified coach may also be permitted with the patron.
- Staff court ratio to active users of performance trampolines shall be at least one to ten.
- Patrons in the performance area shall be instructed where they may sit or stand.

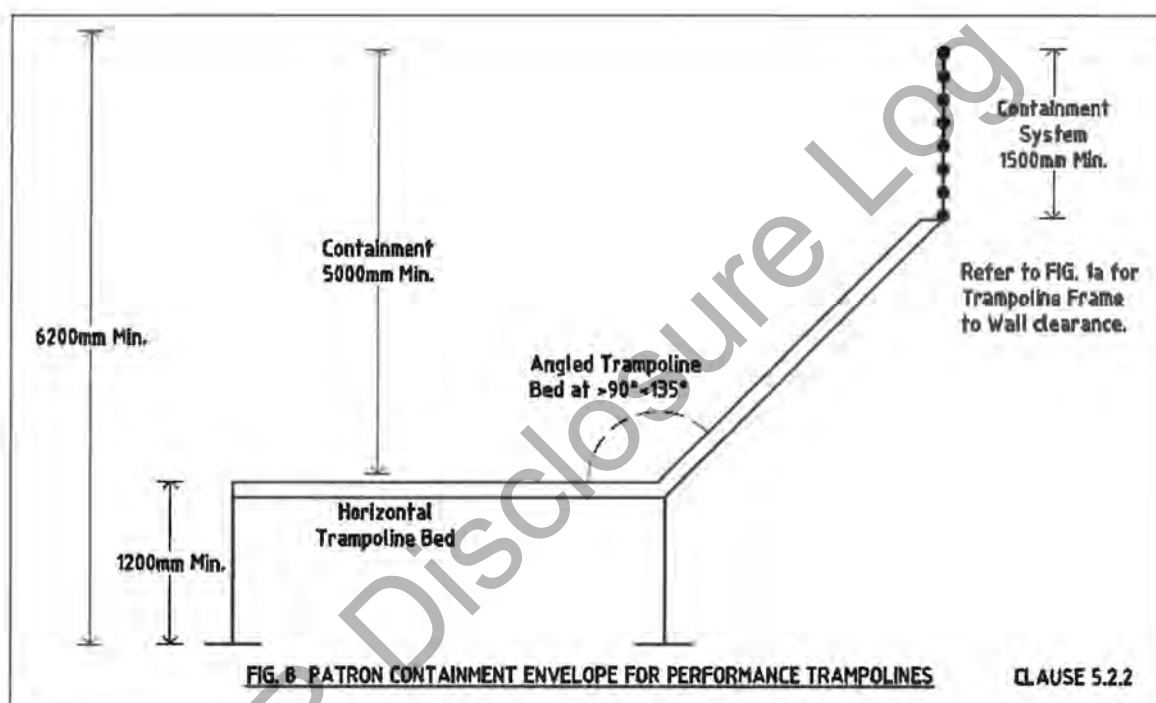

5.6 PATRON EDUCATION

- Instructions, concerning trampoline court rules, shall be delivered to patrons prior to their active participation on the trampoline court.
- Instructions may be delivered to patrons using video, audio, or computer based programs, pre-recorded message, written document, signage, verbal instruction or other delivery method approved by the owner or operator.
- The owner/operator shall convey to intending active participants the substance of the patron responsibility requirements found in the following section 5.7.
- The owner shall ensure that active reinforcement of rules by audio system, or other means, are used at least once during each patron session.

5.7 PATRON RESPONSIBILITY

There are inherent risks in the participation in or on any trampoline court. Patrons of a trampoline park, by becoming active participants, accept the risks inherent in such participation of which a prudent person is or should be aware. Patrons have a duty to exercise good judgment and act in a responsible manner while using the trampoline court and to obey all oral or written warnings, or both, prior to or during participation, or both.

- a) Patrons have a duty to **not** participate on any trampoline court when under the influence of drugs or alcohol.
- b) Patrons have a duty to properly use all trampoline court safety equipment provided.
- c) Patrons have a duty to **not** participate in or on any trampoline court if they have pre-existing medical conditions, including but not limited to circulatory conditions, heart or lung conditions, recent surgeries, back or neck conditions, high blood pressure, any history of spine, musculoskeletal or head injury, or may be pregnant.
- d) Patrons have a duty to remove inappropriate attire, including hard, sharp, or dangerous objects (such as buckles, pens, purses, badges, and so forth).
- e) Patrons have a duty to avoid bodily contact with other patrons.
- f) Patrons have a duty to conform with or meet height, weight, or age restrictions imposed by the manufacturer or owner to use or participate in the trampoline court activity.
- g) Patrons have a duty to avoid crowding or overloading individual sections of the trampoline court.
- h) Patrons have a duty to use the trampoline court within their own limitations, training and acquired skills.
- i) Patrons have a duty to avoid landing on their head or neck. Serious injury, paralysis, or death, can occur even when landing on the trampoline bed, foam pit, air bag or padding.
- j) When required by the operator, patrons are required to use approved socks specified for safe use of the facility

As Patrons will not normally have access to this Code of Practice, then these Patron Responsibility Rules shall be displayed within the public areas of the trampoline park premises or mobile trampoline park site.

5.8 EMERGENCY PROVISIONS AND PROCEDURES

The administration of emergency health care service and treatment should be recorded as deemed appropriate by the owner/operator of the trampoline park in accordance with the requirements of WHS regulations.

Specifically, the owner/operator of a trampoline park shall notify the appropriate Regulator of any incident as outlined below:

5.8.1 The Regulations [**Occupational Health and Safety Act 2004** in Victoria and the **Work Health and Safety Act 2011 (WHS Act)** in all other states] create a duty on persons conducting a business or undertaking to notify their State Regulator immediately after becoming aware that a notifiable incident arising out of the conduct of the business or undertaking has occurred. A notifiable incident under the Act means:

- (a) the death of a person, or
- (b) a serious injury or illness of a person, or
- (c) a dangerous incident.

Further to (b) *serious injury or illness of a person* means an injury or illness requiring the person to have:

- (a) immediate treatment as an in-patient in a hospital, or
 - (b) immediate treatment for:
 - (i) the amputation of any part of his or her body, or
 - (ii) a serious head injury, or
 - (iii) a serious eye injury, or
 - (iv) a serious burn, or
 - (v) the separation of his or her skin from an underlying tissue (such as degloving or scalping), or
 - (vi) a spinal injury, or
 - (vii) the loss of a bodily function, or
 - (viii) serious lacerations, or
 - (c) medical treatment within 48 hours of exposure to a substance,
- and includes any other injury or illness prescribed by the regulations.

- 5.8.2 A person who conducts a business or undertaking must ensure that the regulator is notified immediately after becoming aware that a notifiable incident arising out of the conduct of the business or undertaking has occurred.
- 5.8.3 The notice must be given in accordance with the Regulations and by the fastest possible means.
The notice must be given:
- (a) by telephone, or
 - (b) in writing.
- A person giving notice by telephone must:
- (a) give the details of the incident requested by the regulator, and
 - (b) if required by the regulator, give a written notice of the incident within 48 hours of that requirement being made or in accordance with that regulator's requirements.
- A written notice must be in a form, or contain the details, approved by the regulator.
- 5.8.4 If the regulator receives a notice by telephone and a written notice is not required, the regulator must give the person conducting the business or undertaking:
- (a) details of the information received, or
 - (b) an acknowledgement of receiving the notice.
- 5.8.5 A person conducting a business or undertaking must keep a record of each notifiable incident for at least 7 years or in the case of a minor, for up to 3 years after the minor turns 18, whichever is the greater, from the day that notice of the incident is given to the regulator under this section.
- 5.8.6 The person with management or control of a workplace at which a notifiable incident has occurred must ensure so far as is reasonably practicable, that the site where the incident occurred is not disturbed until an inspector arrives at the site or any earlier time that an inspector directs.
In this clause a reference to a site includes any plant, substance, structure or thing associated with the notifiable incident.
This clause does not prevent any action:
- (a) to assist an injured person, or
 - (b) to remove a deceased person, or
 - (c) that is essential to make the site safe or to minimise the risk of a further notifiable incident, or
 - (d) that is associated with a police investigation, or
 - (e) for which an inspector or the regulator has given permission.
- 5.8.7 The owner/operator of a trampoline park shall notify the appropriate manufacturer(s) of any known incident
- 5.8.8 The manufacturer shall notify the appropriate owner(s)/operator(s) of similar trampoline courts of an incident that resulted in a serious injury as a result of inadequate equipment design, promptly upon the determination by the manufacturer that the incident is significantly repeatable. Such manufacturer notification shall be issued as a service bulletin.
- 5.8.9 As a general principle, operators of trampoline parks, especially those who are members of ATPA or AALARA, will provide information to other operators that will assist in minimising the risk of injury to patrons due to equipment failures or design issues. The purpose of sharing this information is to promote the industry as a safe industry that is active in protecting the welfare of patrons and whose members work together in the interests of safety.

SECTION 6 INSPECTION, MAINTENANCE AND CLEANING

6.1 Information Requirements

The designer, manufacturer, supplier, or installer shall supply to the owner, operator, purchaser or requesting regulatory authority prior to shipment, the following information in accordance with AS 3533.1 2009 and AS 3533.2 2009.

- 6.1.1 Assembly Instructions:
- 6.1.2 Operational Instructions:
- 6.1.3 Maintenance Procedures:
- 6.1.4 Inspection Requirements:
- 6.1.5 Service Bulletins: including any issued post-delivery.

6.2 Specifications for inspection, maintenance and repair

Specifications for inspection, maintenance and repair of the trampoline court and its components shall include, but not be limited to, the following:

- a) A phone number, fax number, or email address to be used by the owner/operator to secure maintenance or operating assistance from the manufacturer.
- b) A list of safety critical components and any recommended Non Destructive Testing required for those components.
- c) Periodic minimum service and component inspection checklists.
- d) Repair, replacement and patching instructions which include recommended methods and materials.
- e) Recommendations for cleaning the trampoline court including but not limited to: trampoline beds, suspension system, frames, impact attenuating materials and coverings, netting, impact attenuating blocks, and foam pits.
- f) Recommendations shall include but are not limited to: product recommendations, frequency, cleaning procedures, and biohazard mitigation.
- g) Description of the recommended daily pre-opening inspection to be performed by court attendants, managers, or maintenance personnel, or a combination thereof, prior to daily operations should include, but not be limited to:
 - a. Obstructions,
 - b. Condition of impact attenuating materials and covers,
 - c. Placement and securement of impact attenuating materials,
 - d. Condition of trampoline beds,
 - e. Condition of suspension system,
 - f. Condition of frame,
 - g. Condition of redundant bed or netting underneath or behind trampoline beds, where used,
 - h. Condition of containment system and netting,
 - i. Condition of any communications devices,
 - j. Condition and placement of signage,
 - k. Condition of any foam pit,
 - l. Fluffing of impact attenuating block material, if so equipped,
 - m. Condition of nets, goals, hoops or other devices, if so equipped,
 - n. Condition of balls, discs or other devices, if so equipped,
 - o. Condition of footwear, if so equipped,
 - p. Condition of emergency response equipment and First Aid kits,
 - q. Condition of assembly area,
 - r. Condition of adjacent platforms entrances, exits, stairways, lifts and ramps.
 - s. Correct inflation of any air bags.
 - t. Correct operation of Air Bag power failure alarm system

- 6.3 **Inspection and Maintenance Program**—Based on the trampoline court manufacturer's recommendations, each owner or operator shall implement a program of maintenance, testing, and inspection, providing for the duties and responsibilities necessary to care for the trampoline court, safety equipment, and the trampoline park facilities.

6.4 Replacement parts for trampoline court equipment shall be:

- a) Procured from the original manufacturer of the trampoline court equipment, using the appropriate manufacturer supplied identifying nomenclature; or
- b) Procured or produced to meet or exceed the manufacturer's minimum specification.

APPENDIX A
METHODS FOR CALCULATION OF STRUCTURAL INTEGRITY
(Normative)

A1 SCOPE

This Appendix specifies the methods for calculating values to satisfy structural integrity requirements of this Code of Practice.

For determination of load combination for static analysis see Paragraph A4.

A2 REQUIREMENTS

Load calculations for each structure and structural element, e.g. connections, foundations and supports, shall take into account the load combinations of Paragraph A4. The preferred method of calculation shall be based on the general principles and definitions for calculation of structural integrity as specified in the appropriate structural building codes. Example calculations of user loads (see Paragraph A5) are included to demonstrate acceptable methods of calculation.

A3 LIMIT STATE

A3.1 General

A3.1.1 Equation

The limit state is expressed as:

$$Y_F \times S \leq R \times Y_M \quad \dots A1$$

Where

Y_F = partial safety factor for loads

Y_M = capacity factor for materials

S = load effect

R = the resistance of the structure

A3.1.2 Uncertainties

Allowance for uncertainties in the actual loads, material properties, and in the models used for determining loads and forces in the structure was made by multiplying by a partial safety factor for loads (Y_F) and capacity factor for materials (Y_M).

A3.1.3 Combined loads

In cases where loads have to be combined and the actual formulation is non-linear Equation A1 shall not be used to calculate limit state.

A3.2 Ultimate limit states

Ultimate limit states are those associated with collapse, or with other forms of structural failure which can endanger the safety of people.

Ultimate limit states requiring consideration include— (a) loss of equilibrium of the structure or any part of it, considered as a rigid body; and (b) failure by deformation, rupture, or loss of stability of the structure or any part of it.

A3.3 Serviceability

Serviceability limit states correspond to states beyond which specified service criteria are no longer met.

Where serviceability requirements are made, the preferred method of calculation shall be based on the principles for serviceability limit state as specified in the appropriate structural codes. Serviceability shall be assessed by an appropriately qualified competent person.

A4 LOAD COMBINATION FOR STATIC ANALYSIS

The following load combinations shall be used for design verification:

$$F_c = Y_{G,c} \times M + Y_{Q,c} \times Q_1 \quad \dots \text{A2}$$

Where

F = load combination

M = permanent load being mass of structure as calculated or measured, in kilograms

Q_1 = variable loads such as user loads or other specific applied loads, in kilograms

$Y_{G,c}$ = partial safety factor for permanent loads to be used in calculations

The following capacity factors for loads shall be used:

$Y_{G,c}$ = 1.0 for favourable effects

$Y_{G,c}$ = 1.35 for unfavourable effects

$Y_{Q,c}$ = 1.0 for favourable effects

$Y_{Q,c}$ = 1.35 for unfavourable effects

NOTE: It is necessary to combine independent variable loads such as wind and user loads. Related loads acting in different directions, such as vertical and horizontal user loads, are also combined.

APPENDIX B
 PHYSICAL TESTING OF STRUCTURAL INTEGRITY
 (Normative)

B1 SCOPE

This Appendix specifies the method for physical testing to satisfy structural integrity requirements of this Code of Practice.

Each structure and structural elements shall be tested to the maximum load combinations. Specimen shall be able to carry the total test load (see Paragraph B3) for at least 5 h at the most extreme temperatures of the intended use location.

B2 PASS/FAIL CRITERIA

After the test, the specimen shall show—

- (a) no cracks;
- (b) no damage;
- (c) no permanent deformation; and
- (d) no connections loosened.

B3 TEST LOAD FOR EQUIPMENT

B3.1 Load combinations for testing

The following load combinations shall be used for testing:

$$F_{\text{tot}} = y_{G,t} \times M + y_{Q,t} \times Q_i \quad \dots \text{B1}$$

Where

F_{tot} = load combination

M = Permanent load being mass of structure as calculated or measured, in kilograms.

Q_i = variable loads such as user loads or other specific applied loads, in kilograms

$y_{G,t}$ = partial safety factor for permanent loads to be used in testing

$y_{Q,t}$ = partial safety factor for variable loads to be used in testing according to Paragraph C2.2 or C2.3

B3.2 Independent variable loads

Wind and user loads shall be combined. Related loads acting in different directions, such as vertical and horizontal user's loads, shall also be combined.

B3.3 Permanent loads

If permanent loads are small, no additional safety factor for permanent loads is required in the tests, otherwise 1.35 shall be used.

B3.4 Safety factor for test on identical series

The following safety factor shall be used for identical series where not every specimen is tested:

$$y_{Q,t} = 1 \text{ for favourable effects}$$

$y_{Q,t} = 2.0$ for unfavourable effects

B3.5 Safety factor for test on a unique product

The following safety factor shall be used where every specimen, including unique products, are tested:

$y_{Q,t} = 1$ for favourable effects

$y_{Q,t} = 1.35$ for unfavourable effects

B4 LOAD APPLICATION

B4.1 Point loads

To simulate the transfer of load caused by one user to the structure, the load should normally be applied over a length of not more than 0.1 m.

The following dimensions shall not be exceeded when applying the loads onto an element of the structure:

Line type element: $l \leq 0.1$ m

Area type element: $a \leq 0.1$ m \times 0.1 m

where

l = support length of the test load, in metres

a = support area of the test load, in metres

B4.2 Line loads

Line loads may be represented by equally distributed point loads spaced not more than 0.6 m apart. The support length under the point loads may be up to 0.6 m.

B4.3 Area loads

Area loads may be represented by equally distributed point loads spaced as a grid with spacings not more than 0.6 m \times 0.6 m. The support area under the point loads shall be less than 0.6 m \times 0.6 m.

B5 TEST REPORT

The test report shall include the following information:

- (a) Identification of the testing body.
- (b) Description of the item(s) tested.
- (c) Test method(s) used.
- (d) Result(s) and conditions that were achieved.
- (e) Date.
- (f) Reference to this test method, i.e. Appendix B of Code of Practice

APPENDIX C
 DETERMINATION OF HIC, HIC DURATION, G_{\max} AND j_{\max} VALUES
 (Normative)

C1 SCOPE

This Appendix sets out the method for determination of the head injury criterion (HIC), HIC duration, G_{\max} and j_{\max} values for impact attenuating system.

C2 PRINCIPLE

The impact attenuation system is impacted by an instrumented headform in a series of ten impacts from the appropriate fall height above the impact attenuation system. The signal emitted by the tri-axial accelerometer during each impact is processed to yield a level of injury severity. The HIC, HIC duration, G_{\max} and j_{\max} values for each impact are calculated and used as pass/fail criteria.

C3 APPARATUS

C3.1 Fall test headform

The fall test headform shall have the following attributes:

- (a) The body of the headform shall be a hemispherical headform with a diameter of 160.0 ± 0.2 mm and a mass of 4.6 ± 0.1 kg.
- (b) The body of the headform shall be made of a material that exhibits no resonant frequencies below 3000 Hz together with very low impact damping properties. Materials that exhibit these properties are—
 - (i) magnesium Alloy K-1A (magnesium alloy K-1A is $0.7 \pm 0.5\%$ zirconium, balance magnesium); and
 - (ii) aluminium alloy 6061-T6.
- (c) The impacting part of the headform between the lower boundary and accelerometer shall be homogeneous and free from voids.
- (d) The headform shall have a finished surface roughness of no less than surface class N11 in accordance with ISO 1302.

C3.2 Accelerometer

A tri-axial accelerometer shall be mounted in the centre of mass of the headform.

NOTE: A moment between the centre of mass and the accelerometer introduces large errors in the measured G-force.

C3.3 Impact measurement equipment

The impact measurement equipment shall have the following characteristics:

- (a) The impact measurement equipment used shall be suitable for measuring, recording and displaying the acceleration and the time duration of the complete impact event.
- (b) The acceleration/time curve shall be displayed for every fall impact and evaluated for any anomalies.
- (c) The instrumentation shall conform to ISO 6487 channel amplitude class 500G and channel frequency class 1000 Hz.

- (d) The instrumentation shall be calibrated against a reference accelerometer at least every two years. Copy of this calibration shall be attached to the Test Report.

C4 TEST CONDITIONS

Laboratory-based tests shall be conducted on representative samples of impact attenuating systems. The sample shall be a facsimile of the installed impact attenuating system i.e. will include padding joints, cover and fastening mechanisms. The test shall be conducted on a concrete substrate.

In situ tests shall be conducted on the impact attenuation system as installed.

C5 TEST PROCEDURE

C5.1 Selecting test positions

C5.1.1 Representative samples

Four impact test positions shall be located on the test specimen or trampoline.

C5.1.2 In situ tests

Each Trampoline Park facility is likely to present a different test situation. It is therefore not possible to set prescriptive test positions for on-site testing. The test positions shall be selected on the basis of trying to establish the 'worst case'. Tests shall be conducted in order to obtain the highest value for HIC and G_{\max} anywhere on the impact attenuating surfacing system.

NOTE: As guidance on the selection of test positions, one impact test should be conducted at a joint in the padding system. If tests are being conducted to check existing surfacing, positions in high traffic areas or high impact areas such as mount and dismount areas should be tested.

C5.2 Specific test procedure

An impact test consists of a series of at least ten impact measurements carried out on the same impact test position from the appropriate fall height (see Clause 3.2.5).

The procedure shall be as follows:

- (a) Position the headform so a test position on the impact attenuating system to be tested is located perpendicularly below the centre of the headform and its fall will result in the appropriate fall height.
- (b) Perform ten sequential impacts on the same test position within a 10 ± 1 minute window to allow for possible compression or degradation of the impact attenuating material.
- (c) Display and record the acceleration/time curve for the complete duration of every fall impact.
- (d) Record the greatest HIC, HIC duration, G_{\max} and j_{\max} values obtained from the ten consecutive impacts.
- (e) Repeat Steps (a) to (d) for the other three test positions.

C6 CALCULATIONS

C6.1 Calculation of G_{\max}

Determine the G_{\max} by measuring the maximum acceleration for every acceleration/time curve.

C6.2 Calculation of HIC

Calculate the head injury criteria (HIC) for every acceleration/time curve from the equation:

$$\text{HIC} = \left[\left(\frac{\int_{t_1}^{t_2} a dt}{t_2 - t_1} \right)^{2.5} (t_2 - t_1) \right]_{\max}$$

for all time intervals (t_2, t_1) with a sampling frequency ≥ 8000 Hz according to ISO 6487 between t_{start} and t_{end}

Where

t_{start} = the time at the start of an impact event when the acceleration of the headform equals or exceeds $2 \pm 0.1G$

t_{end} = the time at the end of an impact event when the acceleration of the headform first equals or falls below $2 \pm 0.1G$

a = the acceleration experienced by the headform and expressed in G (acceleration due to gravity)

t_1, t_2 = two intermediate values of t (t is the time in seconds) between t_{start} and t_{end} such that the function for calculating HIC is maximized

NOTE: The $2G$ limit provides a threshold that accommodates noise in the equipment without interfering with measurements.

C6.3 Calculation of HIC duration

Calculate the HIC duration for every acceleration/time curve by subtracting the HIC integration limits t_1 and t_2 .

C6.4 Calculation of j_{\max}

Calculate the j_{\max} for every acceleration/time curve by obtaining the maximum slope.

C7 TEST REPORT

The test report shall include the following information:

- Identification details of the impact measurement equipment and a copy of the calibration documentation (dated).
- The address, ABN and contact details of the testing organization.
- The address, ABN and contact details of the Trampoline Park facility, product supplier or manufacturer.
- The HIC, HIC duration $(t_2 - t_1)$, j_{\max} , G_{\max} values at each test position together with a description of the associated impact attenuation system including material thickness.
- Acceleration/time pulse curve for each location. The HIC duration (t_1, t_2) and the impact event limits $(t_{\text{end}} - t_{\text{start}})$ shall be shown on the graph.
- A photograph of each test location.
- Reference to this test method i.e. Appendix C of Code of Practice.

APPENDIX D
INSPECTION INFORMATION AND SCHEDULES
(Informative)

D1 SCOPE

This Appendix provides guidance on the content of inspection schedules for trampoline parks.

D2 POST-INSTALLATION

The trampoline park, especially the arena and trampoline courts, should be inspected by a competent person for compliance with this Code of Practice.

This inspection should be carried out before opening the facility for public use.

D3 DAILY ROUTINE INSPECTION

A daily routine inspection should be carried out by the on-site manager or trained delegated staff. This should be carried out on each day the facility is in use and before the public is admitted.

NOTE: It may be necessary to undertake such an inspection before each session in a busy facility, or at regular intervals throughout the day.

Checks specific to the facility should be carried out in accordance with the suppliers' daily routine checklist. At least the following items should be checked as applicable and form part of the daily routine checklist:

- (a) Framework stability and security.
- (b) Perimeter and other protective netting to ensure it is intact, correctly positioned and maintaining its tension.
- (c) Protective padding to ensure it is fitted correctly to all hard features, floors and walls in accordance with the design.
- (d) Equipment (complete with no missing parts).
- (e) Fire doors functioning correctly and fire exit routes free from obstruction.
- (f) Fire-fighting equipment in place.
- (g) Electrical cables safely routed and secured in position.
- (h) Electrical plugs and sockets in good condition with unused sockets protected by childproof covers.
- (i) First-aid box on hand and fully stocked in accordance with its contents list.
- (j) Signage in place and clearly visible.
- (k) Area clean and ready for use.
- (l) Gates, closing and locking devices are operational.
- (m) Area is free of trip/slip hazards.
- (n) Minimum required staff always available, including first aid requirements.

D4 MONTHLY OPERATIONAL INSPECTION

A more detailed inspection should be carried out by the on-site manager or trained delegated staff each month.

Checks specific to the facility should be carried out in accordance with the suppliers' instructions. At least the following items should be checked as applicable and form part of the monthly operational checklist:

- (a) All items in daily checklist.
- (b) Mainframe sections and supports stable and secure.
- (c) PVC covers in good repair, i.e. not showing wear at corners, seams and other pressure points (interior foam should not be exposed and shapes should retain their integrity).
- (d) Bolts, shackles, clips, suspension and tension wires, chains, clamps and other fixing devices properly engaged, secure and free from serious metal wear.
- (e) Load-bearing rope features free from broken links, serious wear and secure at their points of fixing.
- (f) Metal components are free of rust and corrosion.

D5 ANNUAL COMPREHENSIVE INSPECTION

Annual comprehensive inspections should be conducted by a competent person in accordance with the manufacturer's instructions. The inspection should include operating and management procedures as well as the equipment.

If trampoline courts are registered with the State Regulator, this inspection may form part of the annual registration process.

Checks specific to the facility should be carried out in accordance with the suppliers' instructions. At least the following items should be checked as applicable and form part of the annual comprehensive checklist:

- (a) All items in daily and monthly checklists.
- (b) The impact attenuating surfacing performance and the adequacy of the fall zone.
- (c) Structural integrity of the mainframe clamps.
- (d) Structural integrity of the barrier, netting and mesh.
- (e) Fire egress.
- (f) Compliance to this Code of Practice.

APPENDIX E
TEST METHOD FOR BARRIERS, NETTING, MESH AND ATTACHMENT
PERFORMANCE

(Normative)

E1 SCOPE

This Appendix provides guidance on the testing of the barriers, netting, mesh and their attachment performance.

E2 APPLICATION

A typical panel of the contained play equipment shall be tested for—

- (a) structural integrity; and
- (b) attachment (fixing) performance.

E3 APPARATUS

A 90 kg bag approximately 300 mm in diameter by 500 mm long shall be suspended directly above the centre of the panel being tested.

The distance between the pivot point and the centre of gravity shall be 3.0 ± 0.1 m.

The centre of gravity of the bag should be at the mid-point of the bag.

E4 PROCEDURE

The bag shall be lifted through 30 degrees and released.

Two impacts are to be directed at a point at the centre of the barriers, netting, or mesh panel.

The dynamic load shall be applied in a pendulum motion against the barrier as such in Figure E1.

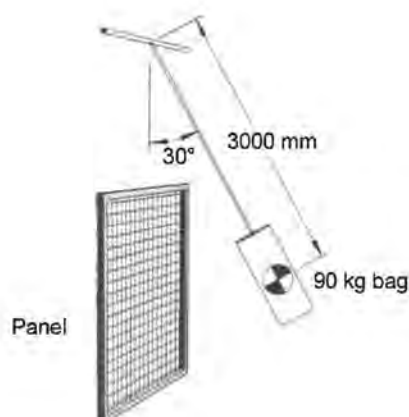

FIGURE E1 BARRER TEST METHOD

E5 PASS/FAIL CRITERIA

After the test, the barriers, netting, or mesh shall show—

- (a) no tearing;
- (b) no net or mesh strand breakage;
- (c) no barrier cracking;
- (d) no breakage/failure of the attachment system; and
- (e) no connections loosened.

If any of these are noted a fail result shall be recorded.

E6 TEST REPORT

The test report shall include the following information:

- (a) Identification of the testing body.
- (b) Description of the item(s) tested.
- (c) Test method(s) used.
- (d) Result(s) and conditions that were achieved.
- (e) Date.
- (f) Compliance with this Code of Practice.

OIR Disclosure Log

APPENDIX F
TEST METHOD FOR ULTRA VIOLET (UV) RESISTANCE
(Normative)

F1 SCOPE

This Appendix sets out the test method for accelerated ageing using ultraviolet (UV) light exposure.

Test exposed and non-exposed (control samples) tensile test samples in accordance with ASTM D 638 v ISO, at a testing rate of 50 mm/min.

F2 PROCEDURE

The samples are to be exposed according to the following procedures: Accelerated Weathering Procedure (Xenon Lamp Exposure). The test procedure shall be in accordance with AATCC Method 169 v ISO, except the following deviations shall apply:

- (a) The apparatus shall be equipped with an automatic light monitor and shall be capable of automatically controlling irradiance, temperature, and humidity.
- (b) The exterior (face) side of the sample shall be exposed to the light source. The weathering test cycle shall be 40 min of light, 20 min of light with water spray on the sample, 60 min of light, 60 min of darkness. The test cycle shall be repeated until the total energy exposure is equal to 500 kJ/m² at 340 nm (or 62 MJ/m² at 300 nm – 400 nm), which is approximately a 500 hour exposure in the test apparatus.
- (c) The irradiance level shall be either: 0.40 ±0.01 W/m² bandpass at 340 nm, or 46 ±1.0 W/m² at 300 nm – 400 nm.
- (d) The glass filter combination shall be a borosilicate type 'S' filter in the inner position and a borosilicate type 'S' in the outer position. Alternate filter combinations are acceptable, provided that the equipment manufacturer provides a letter certifying that the irradiance levels are comparable to those specified within +10%.
- (e) The relative humidity shall be 50 +5% during the light cycle and not less than 95 –0% during the dark cycle.
- (f) The control set points shall be as detailed within Table F1.
- (g) The test specimens shall fit the specimen rack of the apparatus with no wrinkles or gaps. The test specimen shall be mounted on the outside of the rack with the use of appropriate stainless steel spring clips.
- (h) After the required exposure period, the specimens shall be removed from the apparatus and allowed to dry and condition at standard atmospheric conditions.
- (i) Test specimens for each required test shall then be cut and tested appropriately as described in Paragraph F2.

TABLE F1
CONTROL TEMPERATURE SET POINTS

	Dark cycle	Light cycle
Black panel	$38 \pm 1^{\circ}\text{C}$	$77 \pm 1^{\circ}\text{C}$
Black standard	$38 \pm 1^{\circ}\text{C}$	$84 \pm 1^{\circ}\text{C}$
Wet bulb depression	$0 \pm 1^{\circ}\text{C}$	$10 \pm 1^{\circ}\text{C}$

NOTE: This Table should be used as a guide only; it should be adjusted to achieve the required relative humidity

F3 TEST REPORT

The test report shall include the following information:

- (a) The name and address of the testing facility.
- (b) A unique identifier, i.e. report number or code, and the date(s) of testing.
- (c) Sufficient information to be able to uniquely identify the product being tested such as trampoline make, model identification and photograph(s).
- (d) A fail shall be recorded and reported if any non-conformity is noted.
- (e) Compliance or failure of this test method.
- (f) Name and signature of an authorized person.

APPENDIX G
TEST METHOD FOR FRAME-PADDING AND SOFT-EDGE SYSTEMS
(Normative)

G1 PRINCIPLE

The frame-padding system or soft-edge system of the trampoline is impacted by an instrumented missile in a series of ten impacts from a fall height above the top surface of the trampoline frame-padding system or soft-edge system. The signals emitted by the accelerometer(s) in the missile during each impact are processed to yield a level of injury severity. The acceleration pulse of each impact is plotted and the G_{max} is calculated.

NOTE: Figures G1 and G2 contain examples of a single-peak and multi-peak acceleration pulse and the pass/fail criteria.

G2 APPARATUS

G2.1 Impact test missile

The impact test missile shall have the following attributes:

- (a) The body of the hemispherical missile shall be 160.0 ± 0.2 mm dia, with a mass of 4.6 ± 0.1 kg.
- (b) The body of the hemispherical missile shall be made of a material that exhibits no resonant frequencies below 3000 Hz together with very low impact damping properties. Materials that exhibit these properties are—
 - (i) magnesium alloy K-1A (magnesium alloy K-1A is 0.7 percent zirconium, balance magnesium); and
 - (ii) aluminium alloy 6061-T6.
- (c) The impacting part of the hemispherical missile between the lower boundary and accelerometer shall be homogeneous and free from voids.
- (d) The hemispherical missile shall have a finished surface roughness of no less than 25 μm .

G2.2 Missile release mechanism

The hemispherical impact test missile shall be held and released by a device that is located at the test drop height perpendicularly above the surface to be impacted.

G2.3 Accelerometer

A tri-axial accelerometer shall be mounted in the centre of gravity of the missile.

A guided uni-axial accelerometer shall not be used.

NOTE: Uni-axial accelerometers have been shown to give misleading results if the missile is dropped off the centre-line of the support frame tube.

G2.4 Impact measurement equipment

The impact measurement equipment shall have the following characteristics:

- (a) The equipment used shall be suitable for measuring, recording and displaying the acceleration and the time duration of the complete impact.
- (b) The time/acceleration trace shall be displayed for every fall impact and examined for any anomalies before being processed and evaluated.
- (c) The equipment shall conform to Channel Class 1000 of ISO 6487.

© Australian Trampoline Parks Association Rev 1406

G3 TEST CONDITIONS

G3.1 General

The trampoline shall be assembled strictly in accordance with the manufacturer's instructions contained within the packaging and without the enclosure installed (i.e. with the enclosure poles, but not the enclosure barrier).

G3.2 Specific test conditions

G3.2.1 General

The specific trampoline configuration is known to greatly affect the impact attenuating performance of the frame-padding system or soft-edge system. This Paragraph (G3.2) specifies conditions to ensure that the methodology is consistent.

G3.2.2 Trampoline substrate

The tests shall be carried out with the trampoline sited on a concrete substrate.

G3.2.3 Testing position

The testing positions shall be selected on the basis of trying to establish the 'worst case' G_{max} for that trampoline (see Paragraph G4.2 for selection of testing positions).

G3.2.4 Frame-padding system temperature

The temperature of the frame-padding system or soft-edge system shall be $20 \pm 10^{\circ}\text{C}$.

G4 TEST PROCEDURE

G4.1 General

Each trampoline product is likely to present a different test situation. It is therefore not possible to set prescriptive test positions for a generic trampoline. The trampoline shall be randomly selected from a typical manufacturing run and the following test procedure performed. A separate test shall be conducted for each product. For example, where a manufacturer varies the configuration of the frame or padding system, separate certification is required for each configuration.

G4.2 Selecting the test position

The testing positions for each trampoline tested shall be selected on the basis of trying to establish the 'worst case' G_{max} for that trampoline. When selecting the test position the following locations or closest equivalents should be considered:

- (a) Above or adjacent to a support leg (as close as is physically possible to leg).
- (b) Above the spring(s) on either side of the typical support leg.
- (c) Above all bolts, protrusions, and fastening devices on the frame.
- (d) Above all joints within the frame-padding system or soft-edge system.
- (e) Above a frame-brace (if trampoline is fitted with such a member).
- (f) Above the spring(s) adjacent to a frame-brace (if trampoline is fitted with such a member).
- (g) Above a double-butt tube (if trampoline is fitted with such a member).
- (h) Above a joint in the frame-padding system.
- (i) Above or adjacent to the frame-padding attachment system (metal eyelets between pad and frame have been noted to cause increased injury severity).
- (j) Above the suspension system where it attaches to the bed.
- (k) At the enclosure barrier entrance.

Where the manufacturer uses different frame-padding configurations such as different pad thickness, density, or composite materials, the testing body should test a representative sample of each configuration to establish the worst-case configuration.

G4.3 Procedure

G4.3.1 Test procedure for frame-padding systems

The test procedure shall be as follows:

- (a) Select a trampoline randomly from a typical manufacturing run.
- (b) Drop the missile from a height of 1500 +10, -0 mm, or 1200 +10, -0 mm for trampolines that pass the test in Appendix C. Tests should be conducted in areas of worst-case scenario which may or may not be perpendicularly above the centre-line of the tubular frame.

NOTE: Springs may protrude beyond the centre-line of frame tubing and can produce the worst-case scenario for impact. These springs need to be tested in addition to the test above the centre-line of the frame tubing.

- (c) The impact test grouping shall have a tolerance of ± 5 mm along the centre-line of the frame tubing and ± 1.0 mm perpendicular to the centre-line of the frame tubing.
- (d) Repeat the test method ten times or more, with each drop being within five minutes of each other. Repeat the test if the impact lies outside the impact grouping tolerance.
NOTE: Users are funnelled through the enclosure barrier exit/entry system. Repeated usage is known to degrade impact attenuation performance of the frame-padding system.
- (e) Visually inspect the frame-padding system. Any damage, degradation shall be noted and recorded.
- (f) Record the highest value of G_{\max} obtained from the ten impact tests.

G4.3.2 Test procedure for soft-edge systems

The test procedures shall be as follows:

- (a) Select a trampoline randomly from a typical manufacturing run.
- (b) Drop the missile from a height of 1500 +10, -0 mm, or 1200 +10, -0 mm for trampolines that pass the test in Appendix C.
- (c) Repeat the test method ten times or more, with each drop being within 5 minutes of each other. Repeat the test if the impact lies outside the impact grouping tolerance.
- (d) Visually inspect the soft-edge system. Any damage, degradation shall be noted and recorded.
- (e) Record the highest value G_{\max} obtained from the ten impact tests.

G5 TEST REPORT

The test report shall include the following information:

- (a) The name and address of the testing facility.
- (b) A unique identifier, i.e. report number or code, and the date(s) of testing.
- (c) Sufficient information to be able to uniquely identify the product being tested, such as trampoline make, model identification and photograph(s).
- (d) A fail shall be recorded and reported if any non-conformity is noted.
- (e) Compliance or failure of this test method.
- (f) Name and signature of an authorized person.

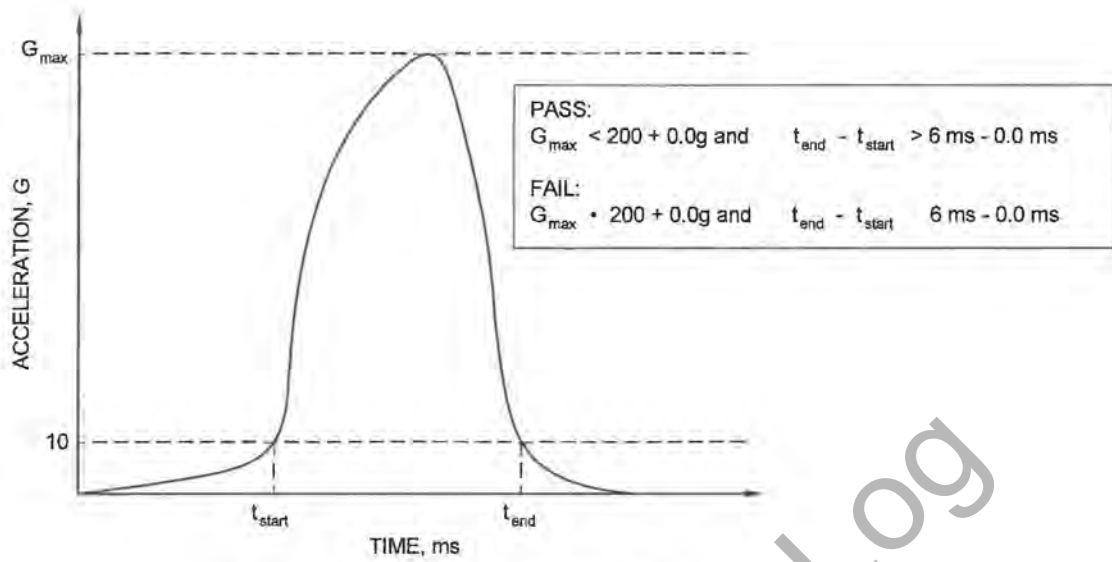

(a) Example of a single-peak acceleration impulse

FIGURE G1 EXAMPLE OF A SINGLE-PEAK ACCELERATION PULSE

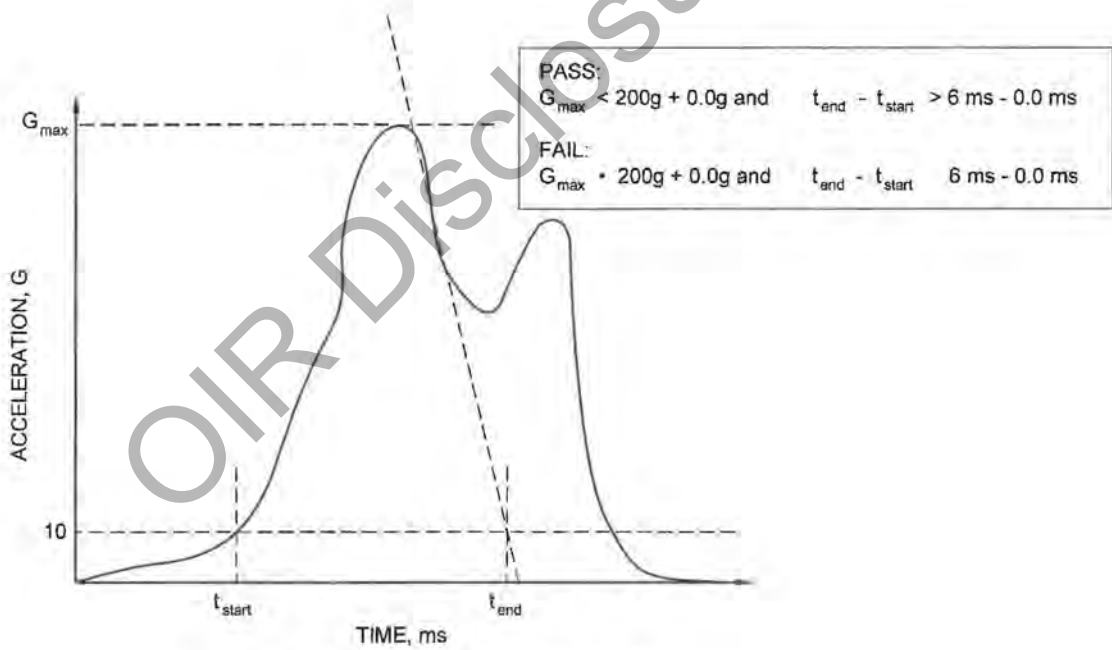

(b) Example of a multi-peak acceleration impulse

FIGURE G2 EXAMPLE OF A MULTI-PEAK ACCELERATION PULSE

APPENDIX H
TEST METHODS FOR ENTRAPMENT
(Normative)

H1 SCOPE

This Appendix specifies the method for physical testing for entrapment.

H2 APPLICATION

All trampolines shall be tested for—

- (a) head, neck and torso entrapment in accordance with Paragraph H4;
- (b) entrapment of clothing, in accordance with Paragraph H6.

H3 TOLERANCES

Unless stated otherwise, tolerances on measurements in this Appendix shall be ± 1 mm for dimensions.

The following tolerances shall apply to the primary pass/fail dimensions of the testing apparatus:

Small probe: $89 + 0.0 - 0.5$ mm \times $157 + 0.0 - 0.5$ mm [see Figure H1 (a)].

Large probe: $230 + 0.5 - 0.0$ mm [see Figure H1 (b)].

H4 HEAD, NECK AND TORSO ENTRAPMENT TEST

H4.1 Apparatus

Small probe and large probe, as illustrated in Figure H1.

H4.2 Procedure

The procedure shall be as follows:

- (a) Apply successively the small probe and large probe shown in Figure H1 to each opening that is 600 mm or more above a standing surface with a force of $220 + 5 - 0$ N.
NOTE: The force may be measured using a spring balance.
- (b) Record and report a fail for any opening that allows the passage of the small probe but does not allow the passage of the large probe.
- (c) Statically load the bed with 3 times the maximum user weight and repeat Steps (a) and (b).

OIR Disclosure Log

H5 ENTRAPMENT OF CLOTHING TEST

H5.1 Apparatus

Test device, as shown in Figure H2 (a), comprising:

- (a) *Toggle*—as shown in Figure H2 (b), made of polyamides (PA) (e.g. nylon) or polytetrafluoroethylene (PTFE), which have been found to be suitable materials.
- (b) *Chain*—as shown in Figure H2(c).
- (c) *Collar*—detachable and with good slip.
- (d) *Pole*.

H5.2 Procedure

The procedure shall be as follows:

- (a) Apply the toggle and chain to all positions within range of the enclosure system.
- (b) Move the test device slowly in the all directions that a user might fall within the enclosure or from the trampoline, ensuring that the application of the toggle or chain is influenced solely by its own weight. Do not apply any additional initial force to wedge the toggle or chain.
- (c) If the toggle or chain gets caught, stop the test and record a fail.

H6 TEST REPORT

The test report shall include the following information:

- (a) The name and address of the testing facility.
- (b) A unique identifier, i.e. report number or code, and the date(s) of testing.
- (c) Sufficient information to be able to uniquely identify the product being tested such as trampoline make, model identification and photograph(s).
- (d) A fail shall be recorded and reported if any non-conformity is noted.
- (e) Compliance or failure of this test method.
- (f) Name and signature of an authorized person.

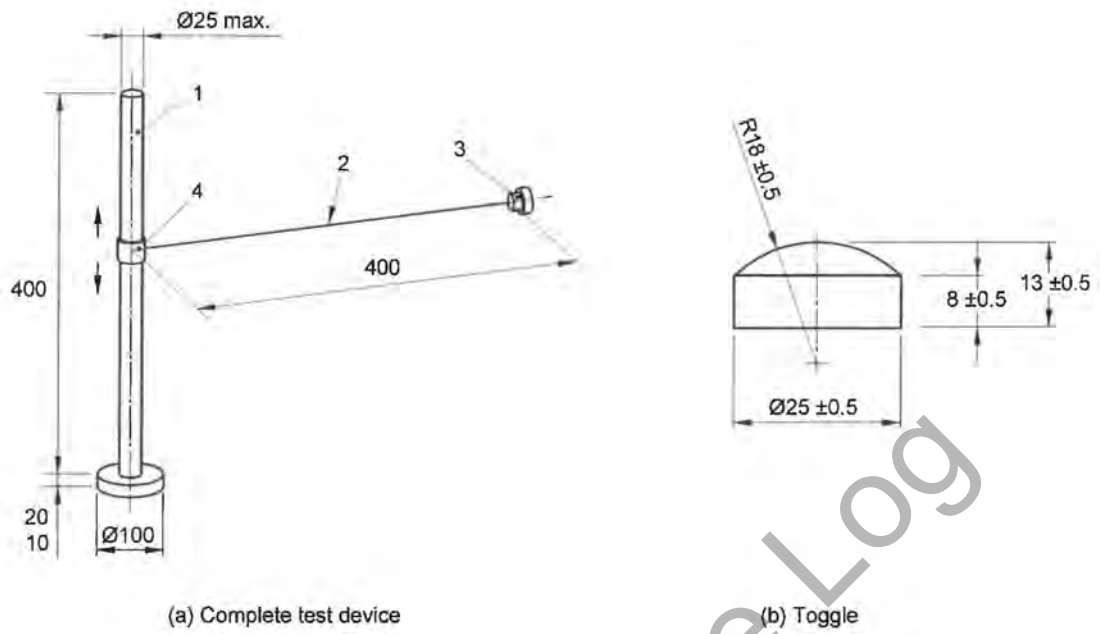

LEGEND:
 1 = Pole
 2 = Chain
 3 = Toggle
 4 = Collar

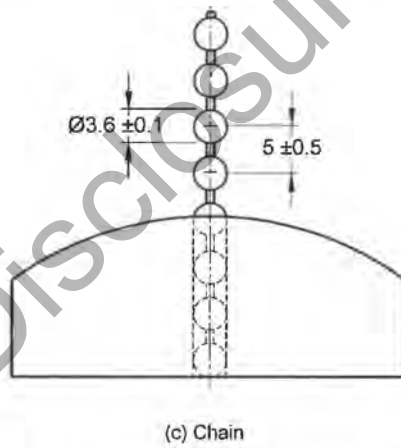

FIGURE H2 CLOTHING TOGGLE TEST DEVICE