

Technical data
Piling and drilling rig

LRB 255
Litronic®

OIR Disclosure Log

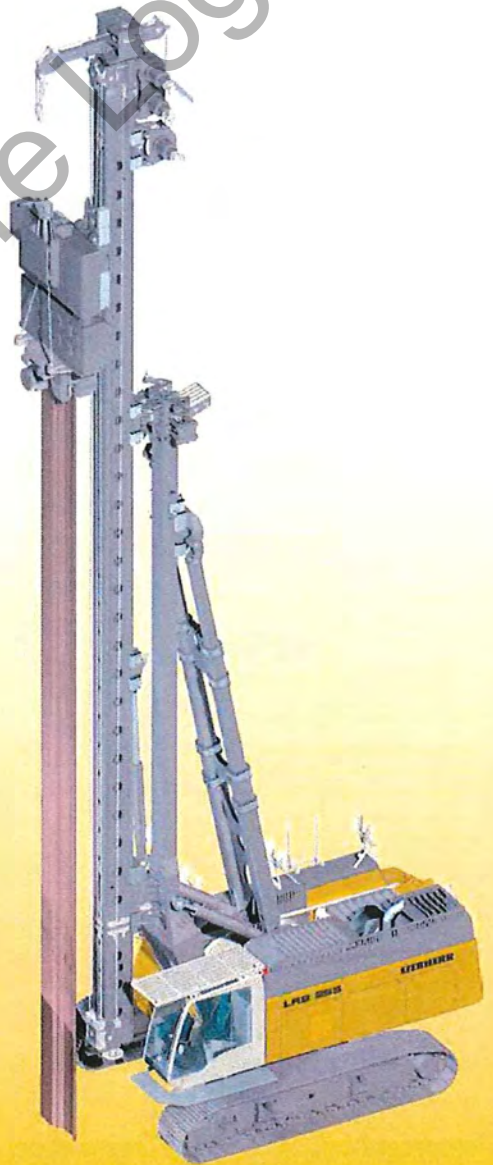

Concept and characteristics

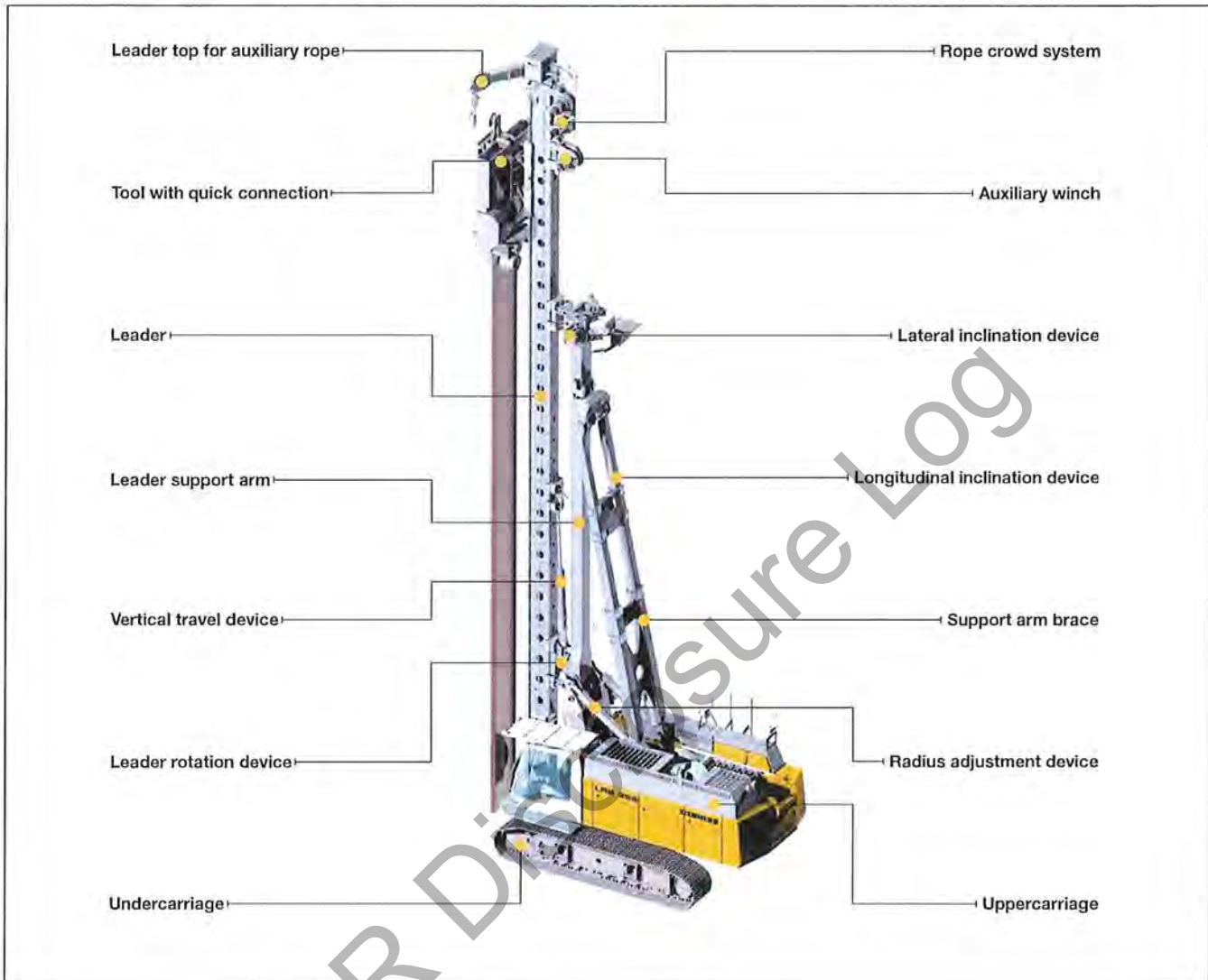

- High engine output with automatic engine speed control
- Controlled entirely from cab
- Sturdy and solid rig design
- Wide longitudinal and lateral supporting system on the basic machine through triangles
- High push and pull forces
- High torque
- Completely self-rigging (no auxiliary machines required)
- Large range of working tools (all piling and drilling works can be performed)
- Stepless leader inclination 1:6 forward – 1:3 backward depending on type of equipment
- Leader swing range $\pm 90^\circ$
- Increase of effective leader length (3 m) via vertical travel device
- Automatic vertical alignment
- High alignment forces
- Simultaneous control of several movements via Load-sensing multi-circuit hydraulics
- Quick change of equipment possible through quick connection
- Equipment design according to latest European regulations and standards
- High manufacturing quality through quality control by PDE®-system

Transport dimensions and weights

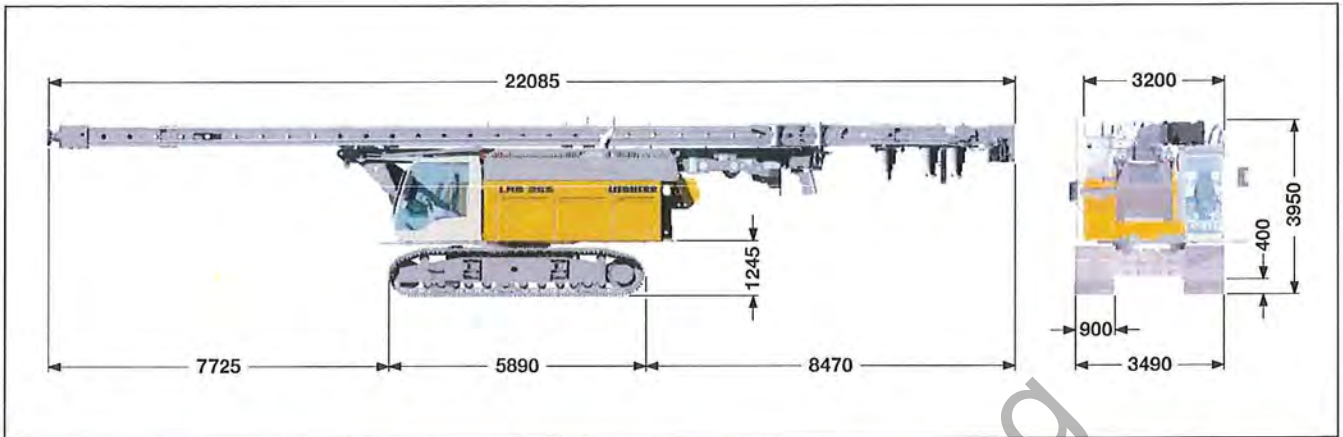

Transport with leader

includes the basic machine (ready for operation) with leader, without working tools (such as rotary, Kelly bar etc.) and without counterweight.

Dimensions and weights

Leader length — 21.2 m — 24.2 m — 27.2 m — 30.2 m
 Weight complete without counterweight — 68.3 t — 69.4 t — 70.6 t — 71.8 t

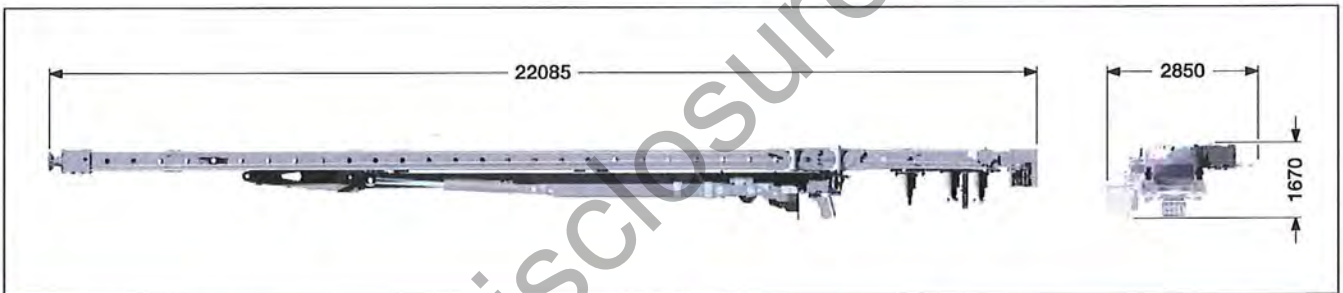

Transport leader

includes the leader without working tools (such as rotary, Kelly bar etc.).

Dimensions and weights

Leader length — 21.2 m — 24.2 m — 27.2 m — 30.2 m
 Weight — 27.3 t — 28.4 t — 29.6 t — 30.8 t

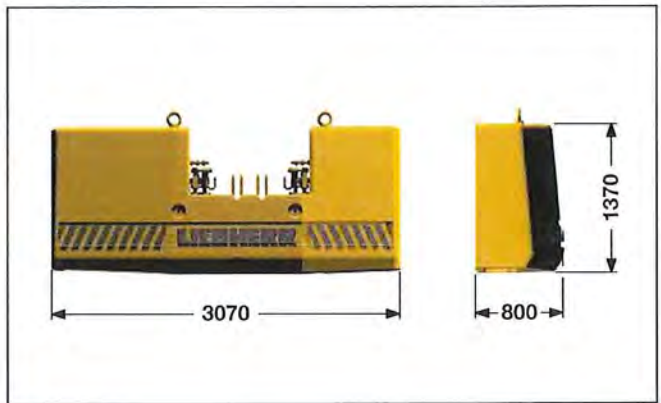
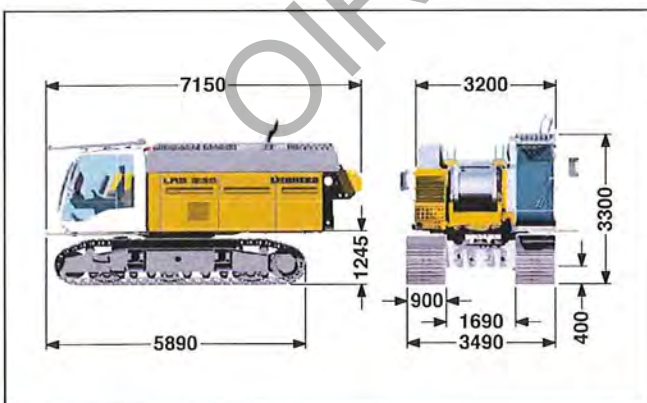

Transport basic machine

ready for operation

Basic machine — 41 t

Weights

Counterweight — 12.5 t

Weights can vary with the final configuration of the machine. The figures in this brochure may include options which are not within the standard scope of supply of the machine.

Dimensions

Basic machine LRB 255

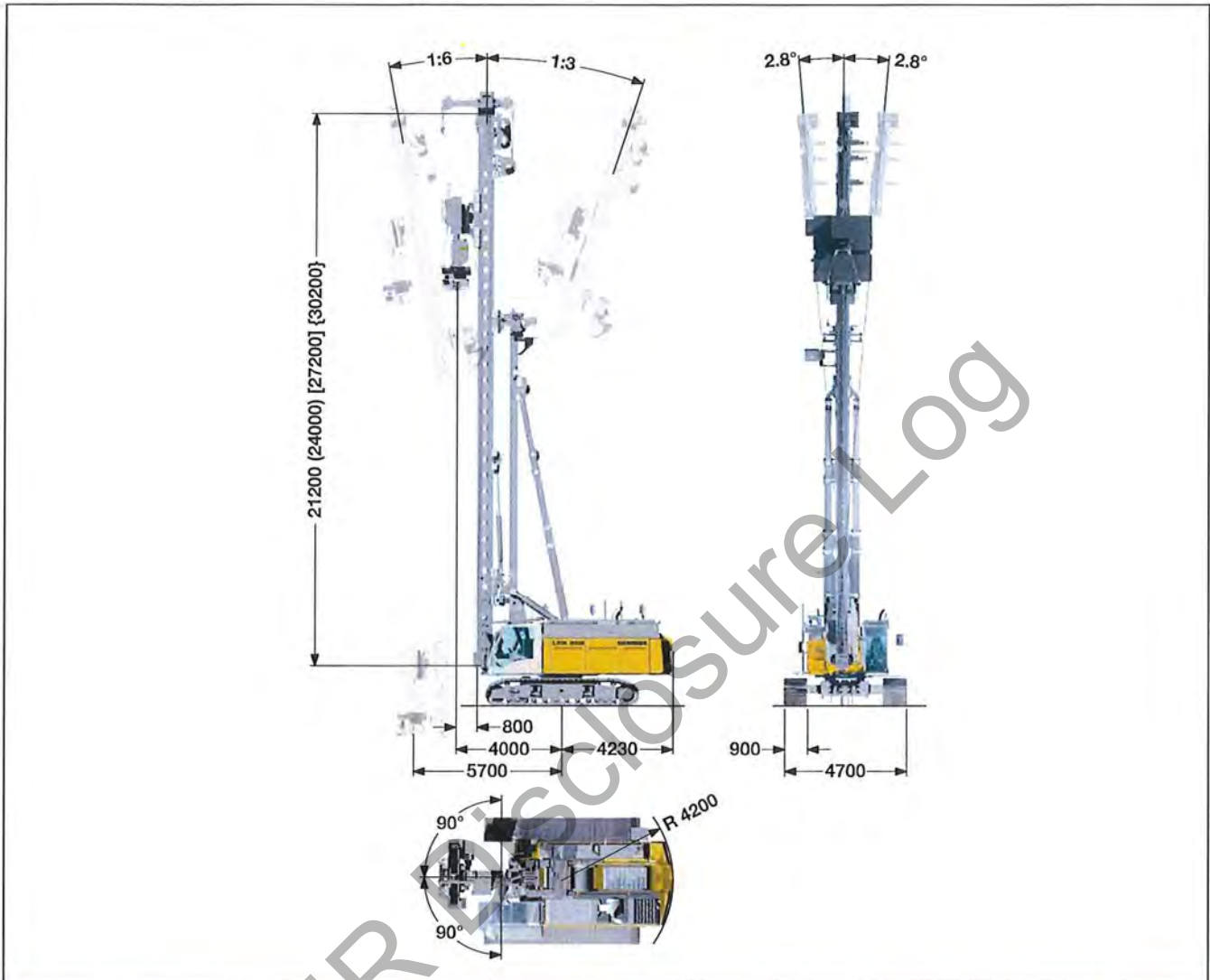

Technical data

Leader length	21/24/27/30 m
Capacity hammer including cap plus pile	30 t
Max. hammer weight	15 t
Max. pile weight	15 t
Max. pull, leader on ground	450 kN
Max. torque	300 kNm
Working radius machine	
center of rotation — front edge leader	3.2 — 4.9 m
Stepless rig inclination adjustment	
Lateral inclination	± 1:20
Forward inclination	1:6
Backward inclination	1:3
Vertical leader adjustment	
above ground level (depending on radius)	3 m
below ground level (depending on leader length)	5 m
Leader swing range	± 90°

Operating weight and ground pressure

Total weight with 900 mm 3-web shoes	80.8 t
Ground bearing pressure	0.91 kg/cm ²
The operating weight includes the basic machine LRB 255 (leader length 21.2 m, without working tools) and 12.5 t counterweight.	

Technical data



Engine

Power rating according to ISO 3046, 670 kW (898 hp) at 1900 rpm
Engine type _____ MAN D 2842 LE
Fuel tank _____ 795 l capacity with continuous level indicator and reserve warning
Engine complies with NRMM exhaust certification EPA/CARB Tier 2.



Hydraulic system

The main pumps are operated by a distributor gearbox. Axial piston displacement pumps work in open circuits supplying oil only when needed (flow control on demand).

The hydraulic pressure peaks are absorbed by the integrated automatic pressure compensation, which relieves the pump and saves fuel.

Pumps for working tools _____ 2x 400 l/min and 1x 350 l/min
Separate pump for kinematics _____ 129 l/min
Separate pump for crowd system _____ 300 l/min
Hydraulic oil tank _____ 1000 l
Max. working pressure _____ 350 bar

No auxiliary power packs are required as application specific hydraulics supply power to all components.

The cleaning of the hydraulic oils occurs via an electronically monitored pressure and return filter.

Any clogging is shown on the display in the cab.

The use of synthetic environmentally friendly oil is also possible.



Crawlers

Propulsion through axial piston motor, hydraulically released spring loaded multi-disc brake, maintenance free crawler tracks, hydraulic chain tensioning device.

Drive speed _____ 0 – 1.5 km/h
Track force _____ 622 kN
Width of 3-web track shoes _____ 900 mm



Swing

Consists of triple-row roller bearing with external teeth and two swing drives, fixed axial piston hydraulic motor, spring loaded and hydraulically released multi-disc holding brake, planetary gearbox and pinion. Selector for 3 speed ranges to increase swing precision. Swing speed from 0 – 4.5 rpm is continuously variable.



Control

The control system – developed and manufactured by Liebherr – is designed to withstand extreme temperatures and the many heavy-duty construction tasks for which this machine has been designed. Complete machine operating data are displayed on a high resolution monitor screen. A GSM modem allows for remote inquiry of machine data and error indications. To ensure clarity of the information on display, different levels of data are shown in enlarged lettering and symbols.

Control and monitoring of the sensors are also handled by this high technology system. Error indications are automatically displayed on the monitor in clear text. The machine is equipped with proportional control for all movements, which can be carried out simultaneously. Two joysticks are required for operation. Pedal control can be changed to hand control.

Options:

- PDE®: Process data recording
- GSM-modem



Main winch with freefall

Line pull (effective) _____ 200 kN
Rope diameter _____ 30 mm
Line speed _____ 0 – 89 m/min



Auxiliary winch

Line pull (effective) _____ 80 kN
Rope diameter _____ 20 mm
Drum diameter _____ 320 mm
Line speed _____ 0 – 48 m/min



Rope crowd system

Crowd force push/pull _____ 450/450 kN
Line pull (effective) _____ 150 kN
Rope diameter _____ 24 mm
Line speed _____ 0 – 87 m/min

The winches are noted for compact, easily mounted design. Propulsion is via a maintenance-free planetary gearbox in oil bath. Load support by the hydraulic system; additional safety factor by a spring-loaded, multi-disc holding brake. All line pull values are effective values. The efficiency factor of approx. 25% has already been deducted.



Noise emission

Noise emissions correspond with 2000/14/EC directive on noise emission by equipment used outdoors.

High frequency vibrator

Model 40 VML with hydraulic sheet pile feeder



Effective length – max. 28 m

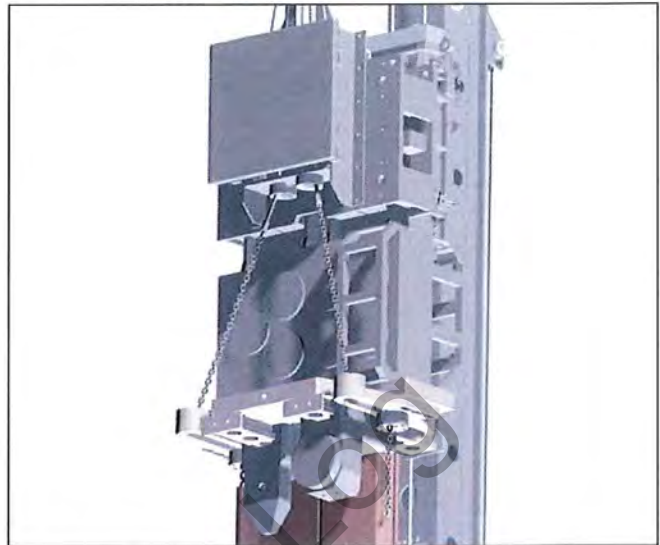

Double clamp and hydraulic sheet pile feeder

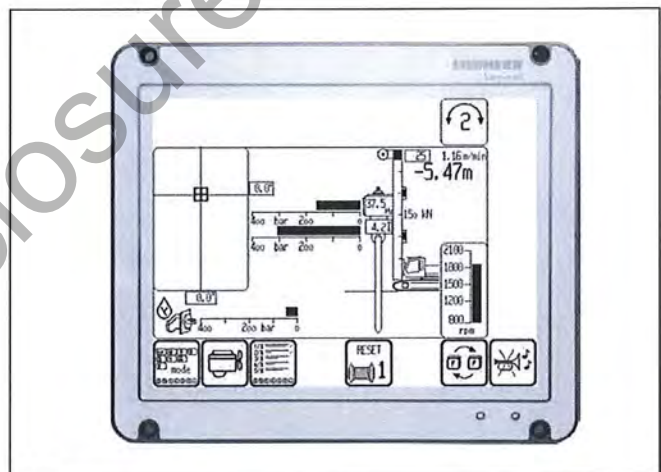

Display for vibrating

Technical data

Static moment	0 – 40 kgm
Max. speed	2000 rpm
Max. centrifugal force	1750 kN
Max. amplitude	0-16 mm
Total weight without clamp	6200 kg
Dynamic weight with clamp	4400 kg
Length	2300 mm
Width	750 mm
Height (without clamp)	2500 mm
Min. width	500 mm

Sheet pile press

Model 4125



Effective length – max. 28 m

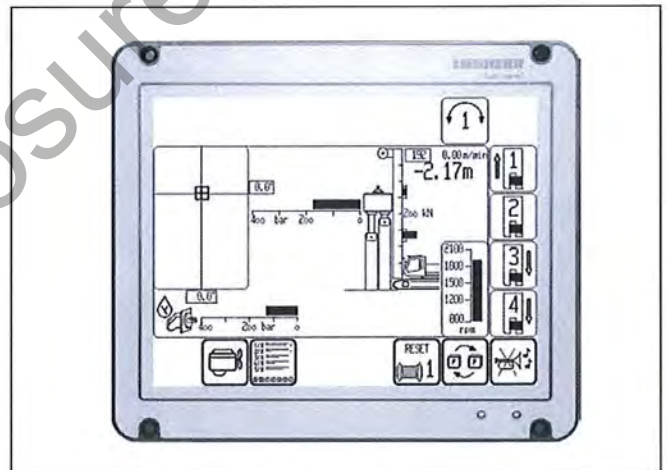

Display for sheet pile press

Technical data

Push force	4x 1250 kN
Pull force	4x 1000 kN
Stroke of cylinders	400 mm
Distance between cylinders	600-670 mm
Working pressure	max. 300 bar
Weight	approx. 9500 kg

High frequency ring vibrator

Model 32 VMR

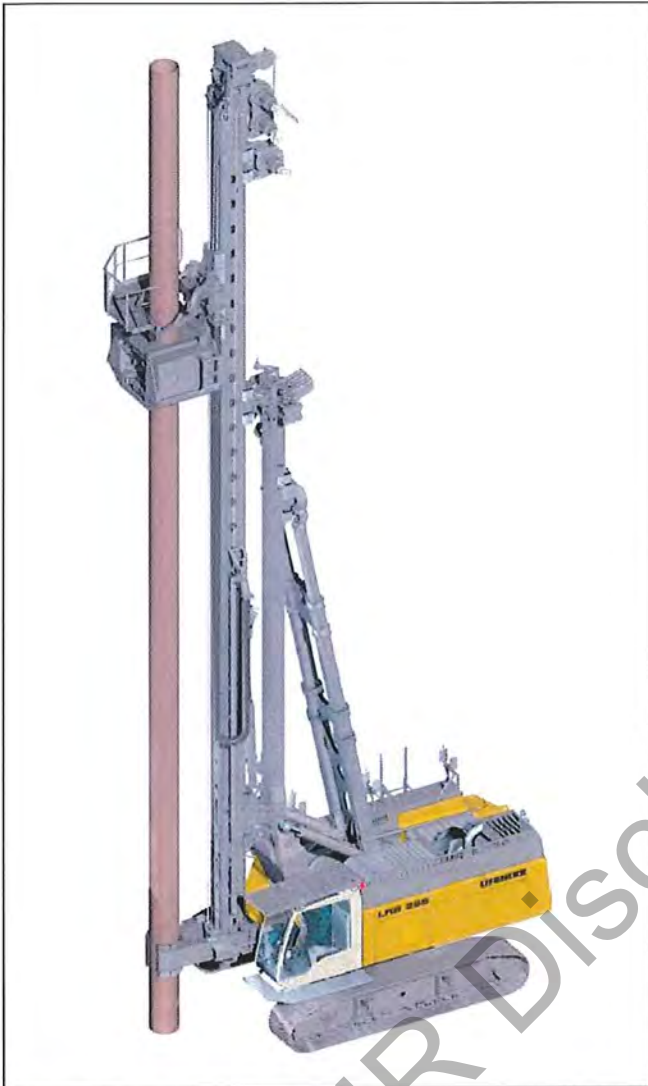

Effective length – 40 m

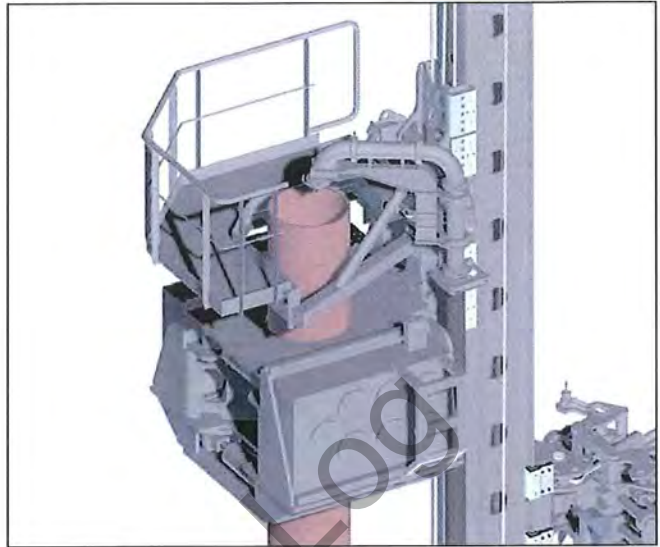

Ring vibrator with platform and concreting system

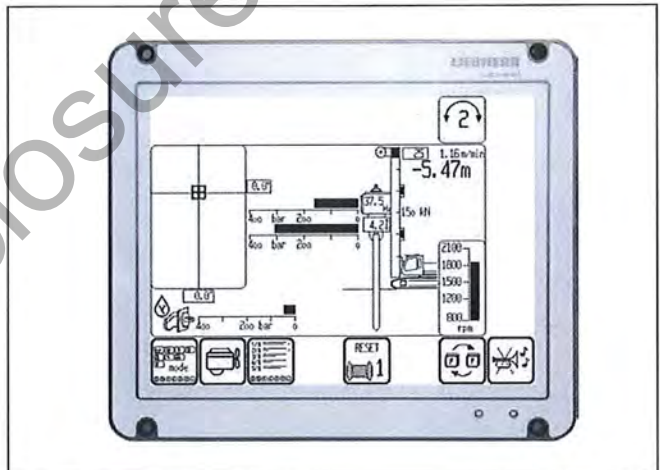

Display for vibrating

Technical data

Static moment	0 – 32 kgm
Max. speed	2300 rpm
Max. centrifugal force	1800 kN
Max. pull force	450 kN
Max. pull down	450 kN
Amplitude	0-5 mm
Casing diameter	356-610 mm
Total weight	12500 kg
Max. hydraulic pressure	350 bar
Hydraulic flow	860 l/min

Hydraulic hammer

Model H 110



Effective length – max. 27 m

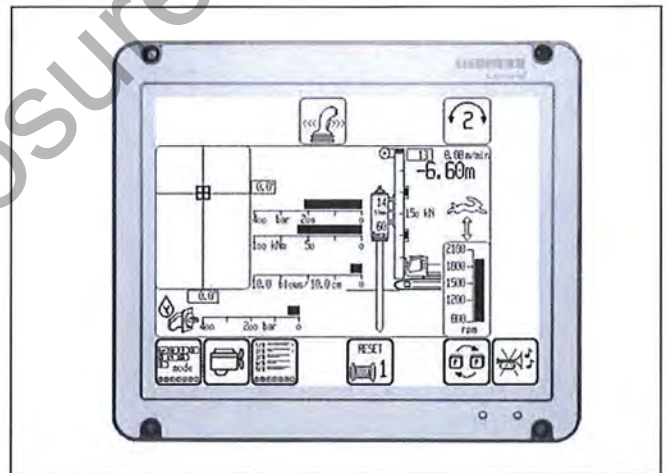

Display for impact driving

Technical data

Hammer model	H 110/9	H 110/7*
Ram weight	9000 kg	7000 kg
Max. rated energy	106 kNm	83 kNm
Blow rate	36-100 blows/min	40-100 blows/min
Hammer weight		
incl. ram	12500 kg	10300 kg
Hydraulic pressure	250 bar	230 bar
Hydraulic flow	215 l/min	215 l/min

*) The 9000 kg ram can be replaced by a 7000 kg ram.

Double rotary drilling

Model DBA 300

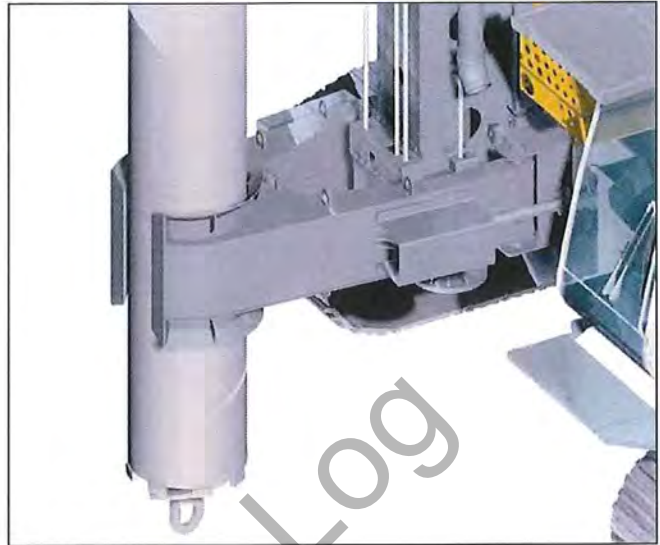

Hydraulic casing guide

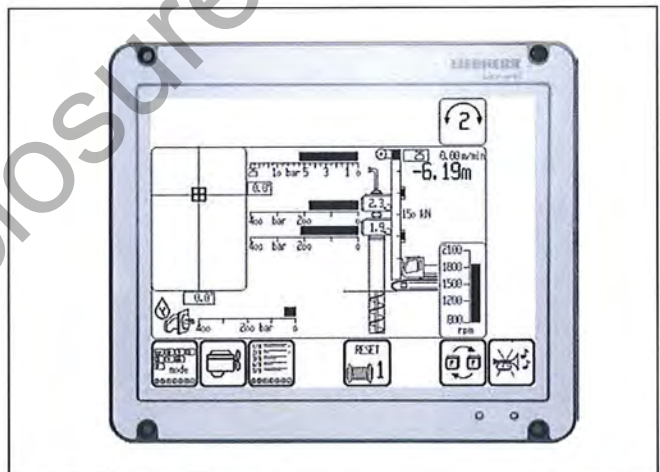

Display for double rotary drilling

Technical data

Drilling drive I – torque	300 kNm
Drilling drive I – speed	26 rpm
Drilling drive II – torque	150 kNm
Drilling drive II – speed	31 rpm

*) Other drilling diameters and drilling depths available on request

Performance data

Max. drilling diameter*	900 mm
Max. drilling depth*	18.5 m
Max. pull force (crowd winch and Kelly winch)	850 kN

Kelly drilling

Model BA 250

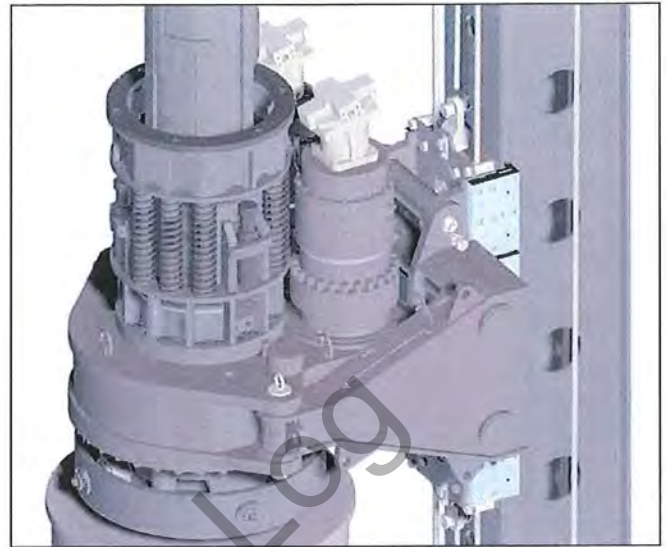
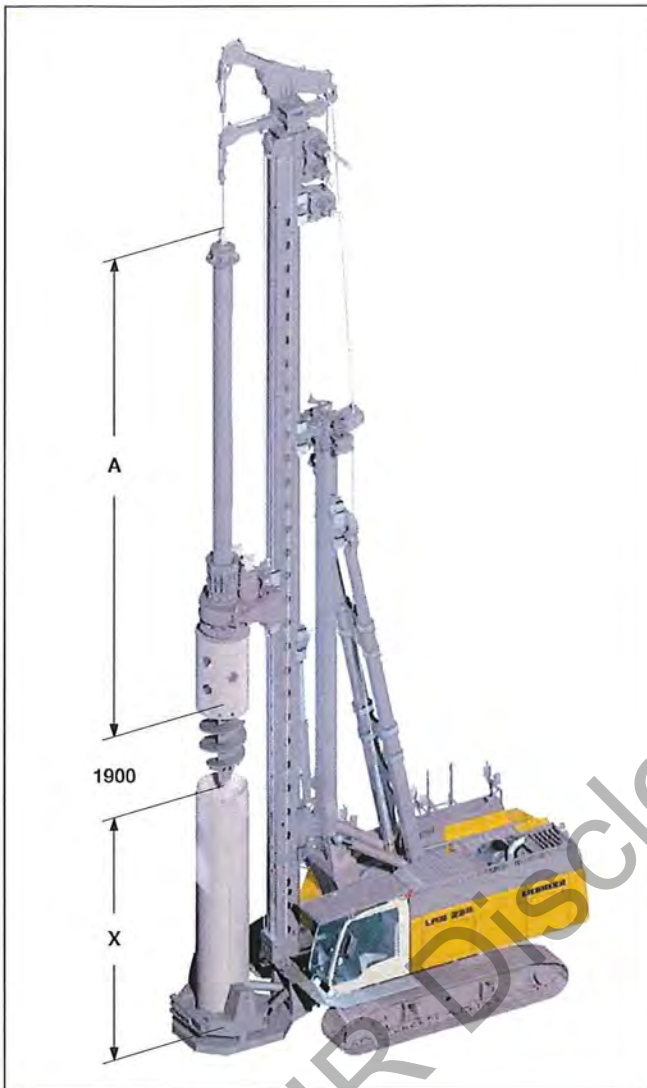

Shock absorber for Kelly bar



Display for Kelly drilling

Technical data

Drilling drive - torque	1 st gear	250 kNm
Drilling drive - speed	1 st gear	25 rpm
Drilling drive - torque	2 nd gear	125 kNm
Drilling drive - speed	2 nd gear	50 rpm

Performance data

Max. drilling diameter*	2200 mm uncased
Max. drilling diameter*	1800 mm cased

*) Other drilling diameters available on request.

Kelly bars

Kelly type	A	X	Drilling depth	Weight	Kelly Ø
	(mm)	(mm)	(m)	(t)	(mm)
MD 28/3/24	9880	12000	21.8	5.0	419
MD 28/3/27	10880	11000	24.8	5.5	419
MD 28/3/30	11880	10000	27.8	5.9	419
MD 28/3/33	12880	9000	30.8	6.4	419
MD 28/3/36	13880	8000	33.8	6.8	419
MD 28/4/36	11450	10750	33.8	7.2	419
MD 28/4/42	12950	9250	39.8	8.1	419
MD 28/4/48	14450	7750	45.8	9.0	419
MD 28/4/54	15950	6250	51.8	9.8	419

Other Kelly bars available on request.

When using a casing oscillator, value X has to be reduced by 1500 mm.

Continuous flight auger drilling

Model BA 250



Effective length – max. 28 m

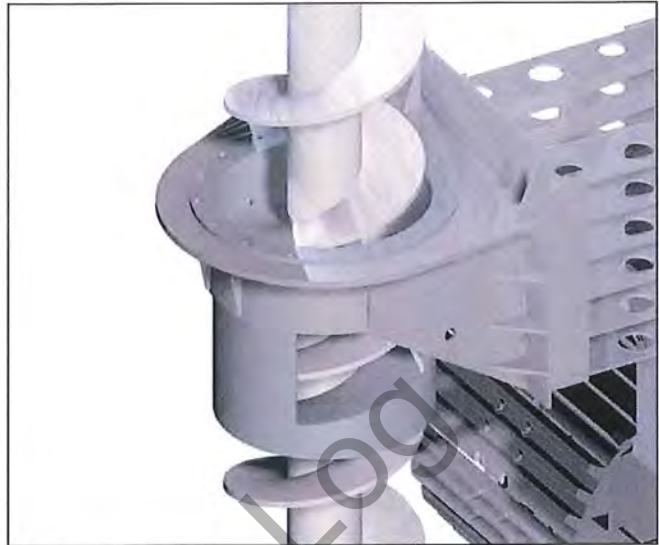

Auger with hydraulic auger cleaner

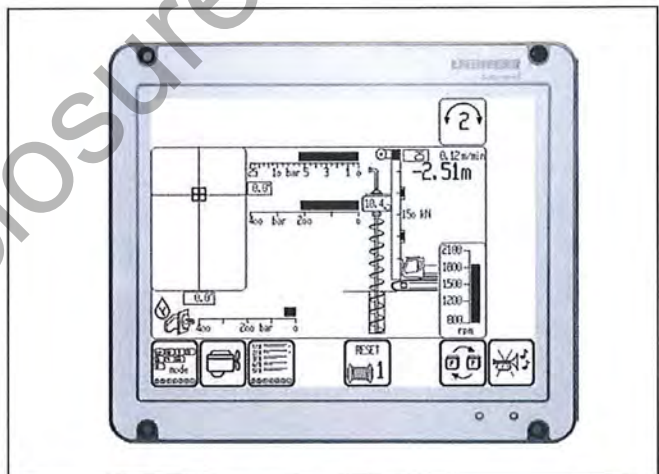

Display for continuous flight auger drilling

Technical data

Drilling drive - torque	1 st gear	250 kNm
Drilling drive - speed	1 st gear	25 rpm
Drilling drive - torque	2 nd gear	125 kNm
Drilling drive - speed	2 nd gear	50 rpm

Performance data

Drilling depth without auger cleaner*	23.0 m
Drilling depth with auger cleaner*	21.5 m
Max. pull force (crowd winch and Kelly winch)	850 kN
Max. push force (weight of rotary and auger to be added)	200 kN
Max. drilling diameter*	1000 mm

*) Other drilling diameters and drilling depths available on request

Process data recording system - PDE® (additional equipment)

The Liebherr process data recording system PDE® constantly records the relevant process data during the working process.

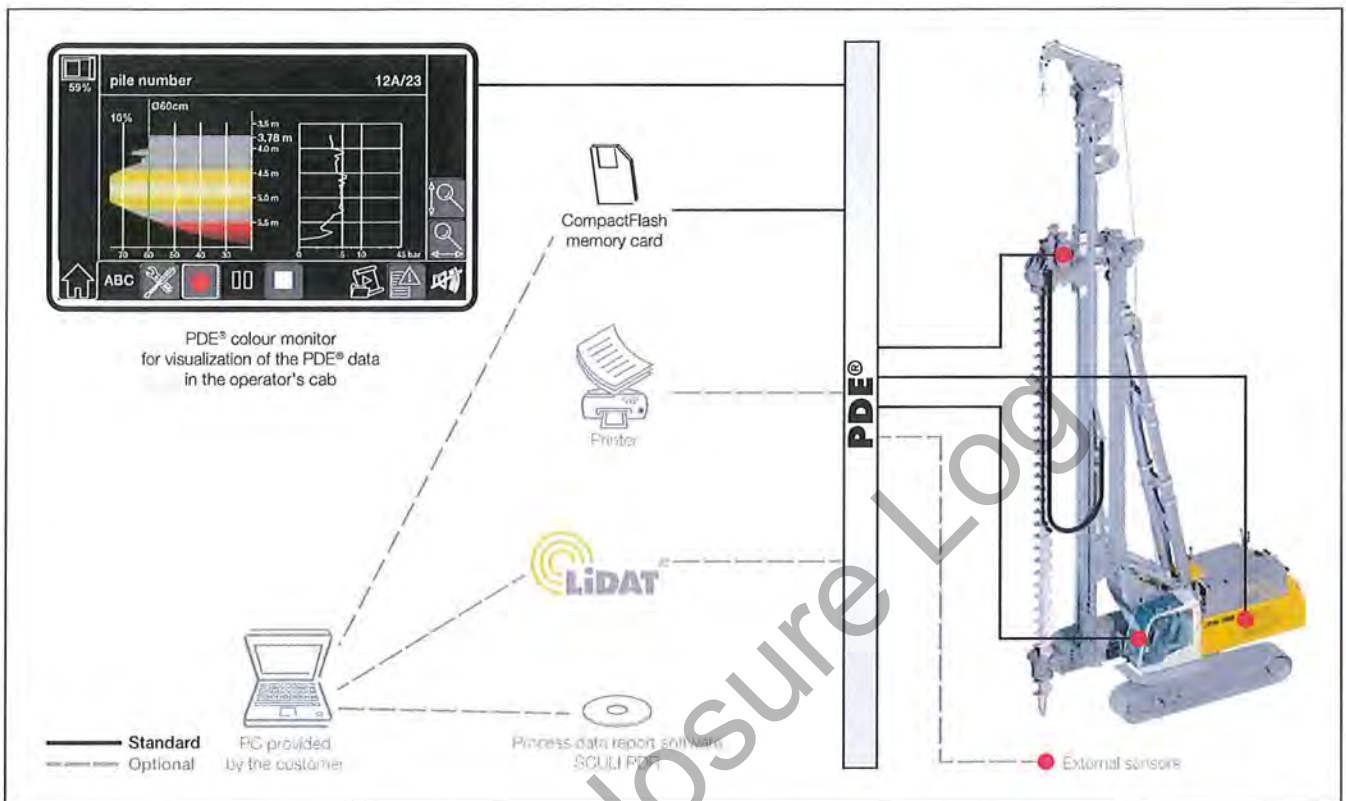

Depending on the application the recorded and processed data are displayed on the PDE® touchscreen in the operator's cab, e.g. in the form of an online cast-in-place pile.

At the same time the PDE® is operated using this touchscreen. The operator can enter various details (e.g. jobsite name, pile number, etc.) and start and stop recordings. A recording of every start-stop cycle carried out in the PDE® is established on a CompactFlash memory card.

The PDE® can be configured in a number of ways, e.g. for the connection of external sensors, for the generation of a simple protocol as graphic file and/or for a printout directly in the operator's cab.

Process data reporting - PDR (additional equipment)

Comprehensive data evaluation and generation of reports on a PC is possible using the software SCULI PDR.

Recordings management - The recordings generated by the PDE® system can be imported and managed in SCULI PDR. The data can be imported directly from the CompactFlash card or via the Liebherr telematics system LiDAT. Certain recordings, e.g. for a particular day or jobsite, can be found using filter functions.

Viewing data - The data in each record is displayed tabularly. Combining several recordings provides results, for example, regarding the total concrete consumption or the average depth. Furthermore, a diagram editor is available for quick analysis.

Generating reports - A vital element of SCULI PDR is the report generator, which allows for the generation of individual reports. These can be printed out directly or stored as pdf files. In the process the size, colour, line thickness or even the desired logo can be configured. Moreover, the reports can be displayed in different languages, e.g. in English and in the national language.

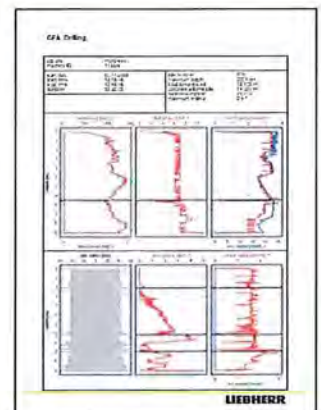

Crane equipment



See technical datasheet HS 845 HD.

Notice

OIR Disclosure Log

OIR Disclosure Log

LRB 255 – 860057014 – 01/2011 Subject to change without notice.